



# Hardware Guide

**VGN-A series**

## *Read this first*

### *Notice*

© 2004 Sony Corporation. All rights reserved.

This manual and the software described herein, in whole or in part, may not be reproduced, translated, or reduced to any machine-readable form without prior written approval.

Sony Corporation provides no warranty with regard to this manual, the software, or other information contained herein and hereby expressly disclaims any implied warranties or merchantability or fitness for any particular purpose with regard to this manual, the software or such other information. In no event shall Sony Corporation be liable for any incidental, consequential, or special damages, whether based on tort, contract, or otherwise, arising out of or in connection with this manual, the software, or other information contained herein or the use thereof.

Macrovision: This product incorporates copyright protection technology that is protected by U.S. patents and other intellectual property rights. Use of this copyright protection technology must be authorized by Macrovision, and is intended for home and other limited viewing uses only unless otherwise authorised by Macrovision.

Reverse engineering or disassembly is prohibited.

In the manual, the <sup>TM</sup> or ® marks are not specified.

Sony Corporation reserves the right to make any modification to this manual or the information contained herein at any time without notice. The software described herein is governed by the terms of a separate user licence agreement.

Please note that the illustrations in this manual may not necessarily apply to your model. Please see the **Specifications** sheet for the specific configuration of your VAIO.

## ENERGY STAR

As an ENERGY STAR Partner, Sony has determined that this product meets the ENERGY STAR guidelines for energy efficiency.

The International ENERGY STAR Office Equipment Program is an international program that promotes energy saving through the use of computers and their office equipment. The program backs the development and dissemination of products with functions that effectively reduce energy consumption. It is an open system in which business proprietors can participate voluntarily. The targeted products are office equipment such as computers, displays, printers, facsimiles and copiers. Their standards and logos are uniform among participating nations.

ENERGY STAR is a U.S. registered mark.



## Environmental information



Halogenated flame retardants are not used in cabinets and in printed wiring boards.

Lead-free solder is used for soldering

Corrugated cardboard is used for packaging cushions.

## Owner's record

The serial number and model number are located on the bottom of your Sony computer. Record the numbers and refer to them if you call VAIO-Link. See also the printed **Specifications** document.

## Safety Information

### General

- ❑ Risk of explosion if battery is replaced by an incorrect type. Dispose of used batteries according to the instructions.
- ❑ Opening the unit, for whatever reason, could lead to damages that are not covered by the guarantee.
- ❑ To avoid electrical shock, do not open the cabinet. Refer servicing to qualified personnel only.
- ❑ To prevent fire or shock hazard, do not expose your VAIO computer to rain or moisture.
- ❑ If reporting a gas leak, do not use the modem or a telephone in the vicinity of the leak.
- ❑ Avoid using the modem during a severe electrical storm.
- ❑ To change the backup battery, please contact your nearest Sony Service Centre.
- ❑ Before you connect peripherals, turn off the computer and all peripherals.
- ❑ Connect the power cord only after connecting all cables.
- ❑ Turn on the computer only after turning off all peripherals.
- ❑ Do not move your computer while the system is in **Standby** mode.
- ❑ The magnetic properties of some objects can have serious consequences for your hard disk drive. They can erase the data on the hard disk drive and cause the computer to malfunction. Do not place your computer near or on any objects which emit magnetic fields, mainly:
  - ❑ TV sets;
  - ❑ Speakers;
  - ❑ Magnets and magnetic bracelets.

## *Audio/video*

Audio and picture distortion may occur if this equipment is positioned in close proximity to any equipment emitting electromagnetic radiation.

## *Connectivity*

- Never install modem or telephone wiring during a severe lightning storm.
- Never install telephone jacks in wet locations unless the jack is specifically designed for wet locations.
- Take care when installing or modifying telephone lines.
- Use your computer only with the supplied AC adapter. To disconnect your computer completely from mains voltage, unplug the AC adapter.
- Make sure that the socket outlet is easily accessible.
- Never touch uninsulated telephone wire or terminals unless the telephone line has been disconnected at the network interface.

## Regulatory information

Sony hereby declares that this product is in compliance with the essential requirements and other relevant provisions of European Directive 1999/5/EC (radio equipment and telecommunications terminal equipment Directive).



### Declaration of Conformity

The European Union is targeting the free movement of goods for the internal market and to prevent technical barriers to trade. This effort has resulted in several EU Directives asking that manufacturers make their products comply with essential standards. Manufacturers are required to affix the "CE" mark on the products they sell and to draw up a "Declaration of Conformity" (DoC).

Primarily, the Declarations of Conformity are intended for the market surveillance authorities as proof that products satisfy the required standards. Additionally, Sony provides these EU DoC's on the website [www.compliance.sony.de](http://www.compliance.sony.de) as a service to our customers.

You can search for all Declarations of Conformity available for a specific product by typing in the model name in the search box. A list of matching documents will be displayed and can be downloaded. Please note that the availability of declarations depends on the scope of the EU Directives and the individual product specifications.

This product complies with EN 55022 Class B and EN 55024 for use in following areas: residential, commercial and light-industrial.

This product has been tested and found compliant with the limits set out in the EMC Directive for using connection cables not longer than 3 metres (9.8 feet). Before activating the built-in modem, please read the **Regulations Guide**.

The optical disc drive is classified as a CLASS 1 LASER PRODUCT and complies with the Laser Product Safety Standard EN 60825-1. Repair and maintenance only by authorised Sony technicians. Improper repairs and use can create safety hazards.

**CLASS 1  
LASER PRODUCT  
TO EN 60825-1**

Your computer may have Bluetooth functionality. Depending on the country, usage of the built-in Bluetooth functionality may be restricted. For country-specific details, please refer to the **Regulations Guide**.

Your computer may have Wireless LAN functionality. If your model is equipped with Wireless LAN, please read the **Regulations Guide** before activating the Wireless LAN functionality. Depending on the country, usage of the **Wireless LAN** functionality may be restricted. For country-specific details, please refer to the **Regulations Guide**. The Wireless LAN PC functionality which is incorporated into this unit has passed Wi-Fi certification, and complies with the interoperability specifications established by WECA (Wireless Ethernet Compatibility Alliance).



## *Disposing of lithium ion batteries*

- Do not handle damaged or leaking lithium ion batteries. Dispose of promptly and properly at end-of-life.
- Danger of explosion if the battery is incorrectly replaced. Replace only with the same or equivalent type recommended by the manufacturer. Discard used batteries according to the manufacturer's instructions.
- The battery pack used in this device may present a fire or chemical burn hazard if mistreated. Do not disassemble, heat above 60°C (140°F) or incinerate.
- Dispose of used batteries promptly and properly.
- Keep away from children.
- In some areas the disposal of lithium ion batteries in household or business waste may be prohibited.
- Use the public collection system.

## *Disposing of internal memory backup battery*

- Your computer is equipped with an internal memory backup battery that should not have to be replaced during the lifetime of the product. For changing this battery, please contact VAIO-Link.
- Danger of explosion if the battery is incorrectly replaced.
- Dispose of properly at end-of-life.
- In some areas the disposal of lithium ion and other non-hazardous batteries in household or business waste may be prohibited.
- Please use the public collection system.



## Welcome

Congratulations on purchasing a Sony VAIO computer. Sony has combined leading-edge technology in audio, video, computing and communications to provide you with state-of-the-art personal computing.

Here are the main features you can enjoy:

- ❑ **Exceptional performance.**
- ❑ **Portability** – The rechargeable battery pack provides hours of use without AC power.
- ❑ **Sony audio and video quality** – A The high-resolution LCD screen and high-quality external stereo speakers\* enables you to take advantage of today's advanced multimedia applications, games, and entertainment software.
- ❑ **Multimedia features** – Enjoy audio and video CDs/DVDs.
- ❑ **Interconnectivity** – Your computer has Memory Stick, Ethernet, USB 2.0 (High-speed/Full-speed/Low-speed) and i.LINK functionalities. i.LINK is a bidirectional digital interface for exchanging data. With the Memory Stick you can easily exchange and share digital data with compatible products.
- ❑ **Wireless technology** – Thanks to Bluetooth\* functionalities and Wireless LAN (IEEE 802.11b/g) technology, you can communicate freely, without cables or wires.
- ❑ **Wireless setup** – Enjoy the freedom of having a mouse without cables\*.
- ❑ **VAIO Zone** – Take advantage of the new **VAIO Zone** technology, allowing you to watch TV and record your favourite programs digitally and by remote control\*.
- ❑ **Windows** – Your system includes the latest operating system from Microsoft.
- ❑ **Communications** – Access popular online services, send and receive e-mails, browse the internet.

- ❑ **Excellent customer support** – If you are experiencing any problems with your computer, please check the VAIO-Link website for a possible solution:  
[www.vaio-link.com](http://www.vaio-link.com)  
Before contacting VAIO-Link, please try to solve the problem by reading this guide, your printed **Guide to Troubleshooting and Recovering your VAIO System**, or the manuals and help files for the peripherals or software.  
Or go to **Start > Help and Support** for VAIO support information as well as tips and tricks.

\* Depending on your model. Read the printed **Specifications** document for more information.



## Documentation pack

Your documentation pack contains printed information and user guides to read on your computer.

Guides are provided in PDF format, which you can easily browse through and print out.

The **My Info Centre** portal is a perfect starting point to using your VAIO - a comprehensive collection of everything you need to get the most from your PC.

The user guides are collected under **My Documentation**, which can be shown as follows:

- 1 Go to **Start** and click the **My Info Centre** icon\* .
- 2 From **My Home**, select your country and language from the drop-down boxes.
- 3 From the pictures at the top of the window click **My Documentation** .
- 4 Select the guide you want to read.

\* The My Info Centre icon is only visible after you have performed the **Prepare your VAIO** setup.

 You can manually browse to the user guides by going to **My Computer > VAIO (C:) (your C drive) > My Documentation > Documentation** and opening the folder for your language.

You may have a separate disc for the documentation of bundled accessories.

## *Printed documentation*

- ❑ A **Getting Started** brochure, where you will find a brief description of the items in your box and how to setup your computer.
- ❑ A **Specifications** sheet, containing a table of specifications, a list of bundled software, an overview of all connectors and, on the reverse side, a guide to setting up your VAIO.
- ❑ A **Guide to Troubleshooting and Recovering your VAIO System**, where you will find solutions to common problems, an explanation of how to recover your computer's system if you need to, and VAIO-Link information.
- ❑ Your **Sony Guarantee conditions**.
- ❑ Booklets containing the following information: **Safety Regulations**, **Modem Regulations**, **Wireless LAN Regulations**, **Bluetooth Regulations\*** and **Wireless Product Regulations\***.

\* Depending on your model. Read the printed **Specifications** document for more information.

## *Non-printed documentation*

**My Documentation** contains the following VAIO user guides:

- ❑ The **Hardware Guide** (this guide) explains the features of your VAIO in detail, how to use these features confidently and safely, connect peripheral devices, upgrade your computer, and more.
- ❑ The **Software Guide** describes how to register your VAIO, the software features available with VAIO systems, how to change settings, how to manage drivers, and more.
- ❑ The **VAIO Zone** guide explains the valuable features of VAIO's multimedia portal. If your computer has TV tuner functionalities, this is where you will find information about watching/recording TV on your VAIO.

**My Documentation** also gives you:

- ❑ Help files about reading the guides.
- ❑ Important information about your computer, in the form of notices and announcements.

In **My Info Centre** you can also find:



### **My Software**

Feeling creative? Click this icon for an overview of your software and check out our upgrade options.



### **My VAIO essentials**

Want to expand the capabilities of your VAIO? Click this icon and have a look at your compatible accessories.



### **My Websites**

Click this icon and check out our most popular websites.



### **My ISP**

Click this icon to find out about the preferential offers from our partners and access the world of the internet.

### *Further sources*

- 1 Go to **Start > Help and Support** for VAIO support information as well as tips and tricks.
- 2 Consult the **Online Help** files of the software you are using for detailed information on features and troubleshooting.
- 3 Go to [www.club-vaio.com](http://www.club-vaio.com) to find online tutorials about your favourite VAIO software.

## Ergonomic considerations

You will be using your computer as a portable device in a variety of environments. Whenever possible, you should attempt to take account of the following ergonomic considerations to both stationary and portable environments:

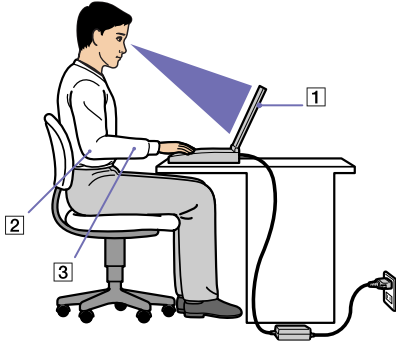

- ❑ **Position of your computer** – Place the computer directly in front of you (1). Keep your forearms horizontal (2), with your wrists in a neutral, comfortable position (3) while using the keyboard or touchpad. Let your upper arms hang naturally at your sides. Have breaks during sessions with your computer. Excessive use of the computer may strain muscles or tendons.
- ❑ **Position of the mouse** – Keep your forearms horizontal, with your wrists in a neutral, comfortable position if you are using a mouse\* – not at an angle. Let your upper arms hang naturally at your sides. Place the mouse at the same level as the keyboard of your computer and use your whole arm to move it.
- ❑ **Furniture and posture** – Sit in a chair with good back support. Adjust the level of the chair so your feet are flat on the floor. A footrest may make you more comfortable. Sit in a relaxed, upright posture and avoid slouching forward or leaning far backwards.
- ❑ **Viewing angle of the computer's display** – Use the display's tilting feature to find the best position. You can reduce eye strain and muscle fatigue by adjusting the tilt of the display to the proper position. Adjust the brightness setting of the display as well.

- ❑ **Lighting** – Choose a location where windows and lights do not create glare or reflection on the display. Use indirect lighting to avoid bright spots on the display. You can also purchase accessories for your display that help reduce glare. Proper lighting adds to your comfort and work effectiveness.
- ❑ **Positioning an external display** – When using an external display, set the display at a comfortable viewing distance. Make sure the display screen is at eye level or slightly lower when you are sitting in front of the screen.



## Using your VAIO computer

Once you have read and followed the information in the printed **Getting Started** guide and **Specifications** sheet, you can start using your computer safely and confidently.

Read on to get the most out of using your VAIO computer.

- ❑ **Connecting a power source** ([page 17](#))
- ❑ **Setting up your computer with Sony Notebook Setup** ([page 22](#))
- ❑ **Shutting down your computer safely** ([page 24](#))
- ❑ **Using the keyboard** ([page 25](#))
- ❑ **Using the touchpad** ([page 28](#))
- ❑ **Using the TV function** ([page 29](#))
- ❑ **Using the mouse** ([page 30](#))
- ❑ **Using special buttons** ([page 33](#))
- ❑ **Using the disc drive** ([page 35](#))
- ❑ **Using PC Cards** ([page 41](#))
- ❑ **Using the Memory Stick** ([page 44](#))
- ❑ **Using the modem** ([page 47](#))
- ❑ **Using the Bluetooth functionality** ([page 48](#))
- ❑ **Using Wireless LAN (WLAN)** ([page 53](#))
- ❑ **Using power saving modes** ([page 60](#))

## Connecting a power source

You can use either an AC adapter or a rechargeable battery pack as a power source.

### Using the AC adapter

To use the AC adapter, proceed as follows:

- 1 Plug the cable attached to the AC adapter (1) into the DC In connector (2) on the computer or on the docking station if you are using one.
- 2 Plug one end of the power cord (3) into the AC adapter.
- 3 Plug the other end of the power cord into an AC outlet (4).

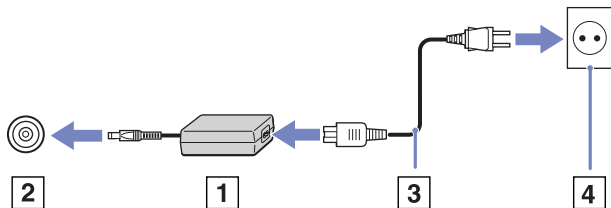

 Use your computer only with the supplied AC adapter.

To disconnect your computer completely from mains voltage, unplug the AC adapter.

Make sure that the socket outlet is easily accessible.

If you do not use the computer for a long period of time, put your computer into **Hibernate** mode. This power saving mode saves you the time of shutting down in the normal way.

## Using the battery pack

Check the **Specifications** sheet for the life time of your battery. Additional battery packs are available as a separate option. The battery pack supplied with your computer is not fully charged at the time of purchase.

A tool is installed on your machine to check if you use a genuine Sony battery designed for this model. When a different kind of battery is detected and your notebook is:

1. off or in **Hibernate** mode: your computer does not start and the battery does not charge. Replace the battery with a genuine Sony battery.
2. on: you receive the following pop-up message: **This battery cannot be used with your computer. Please use only genuine Sony batteries compatible with this computer. Click "OK" to put your computer into Hibernate mode. When your computer hibernates, remove the battery, and insert a genuine Sony battery.** Click **OK**. Your computer enters **Hibernate** mode. Replace the battery with a genuine Sony battery.

! Certain rechargeable batteries do not meet Sony quality and safety standards. For safety reasons this notebook only functions with genuine Sony batteries designed for this model. When inserting another kind of battery, the battery will not be charged and the notebook will not function.

## Inserting the battery pack

To insert the battery pack, proceed as follows:

- 1 Slide the lock lever (1) on the bottom of the computer to the **UNLOCK** position.
- 2 Slide the release lever (2) on the bottom of the computer to the **RELEASE** position.

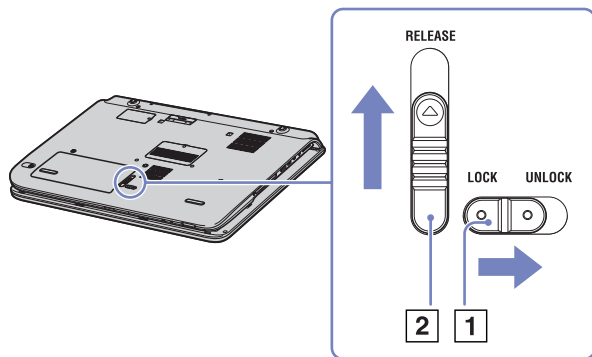

- 3 Remove the battery compartment cover.
- 4 Slide the battery into the battery compartment cover.

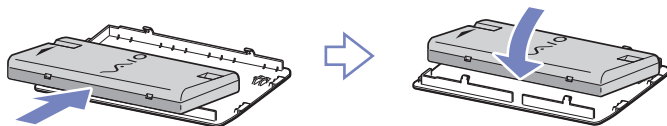

- 5 Insert the tab on the battery into the notch and push the battery down into the compartment until it clicks into place.
- 6 Slide the lock lever to the **LOCK** position to secure the battery on the computer.

 When the computer is directly connected to AC power and has a battery pack inserted in the battery bay, it uses power from the AC outlet.

## Charging the battery pack

To charge the battery pack, proceed as follows:

- 1 Connect the AC adapter to the computer or docking station.
- 2 Insert the battery pack.

The computer automatically charges the battery (the battery indicator light flashes in a double blink pattern as the battery charges).

<i>Battery indicator light status</i>	<i>Meaning</i>
On	The computer is using battery power.
Single blink	The battery is running out of power.
Double blink	The battery is charging.
Off	The computer is using AC power.

 When the battery is running out of power, both the battery and power indicators blink.

Keep the battery pack in the computer while it is directly connected to AC power. The battery pack continues to charge while you are using the computer.

If the battery level falls below 10%, you should either attach the AC adapter to recharge the battery or shut down your computer and insert a fully charged battery.

The battery pack supplied with your computer is a lithium ion battery and can be recharged any time. Charging a partially discharged battery does not affect battery life.

The battery indicator light is on while you use the battery pack as a power source. When the battery life is nearly depleted, both the battery and power indicators start flashing.

For some software applications and some peripheral devices, your computer may not enter **Hibernate** mode even when battery life is low. To avoid loss of data when using battery power, you should save your data frequently and manually activate a power management mode, such as **Standby** or **Hibernate**. If the battery runs down when your computer enters **Standby** mode, you will lose any unsaved data. Going back to the previous work state is not possible. To avoid loss of data, you should save your data frequently.

When the computer is directly connected to AC power and has a battery pack inserted in the battery bay, it uses power from the AC outlet.

## Removing the battery pack

To remove the battery pack, proceed as follows:

- 1 Turn off the computer.
- 2 Slide the lock lever (1) on the bottom of the computer to the **UNLOCK** position.
- 3 Slide the release lever (2) on the bottom of the computer to the **RELEASE** position.

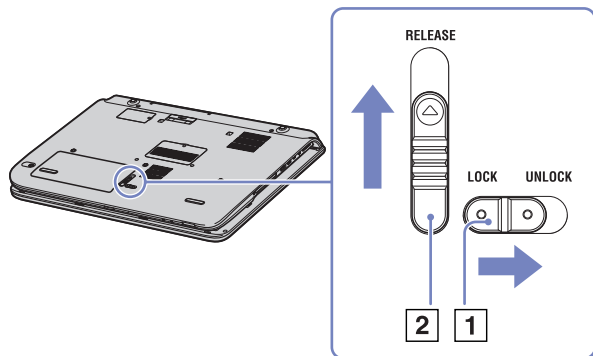

- 4 Remove the battery compartment cover.
- 5 Remove the battery from the compartment.
- 6 Slide the battery compartment cover back over the battery compartment.

 You may lose data if you remove the battery pack while the computer is on and not connected to the AC adapter or if you remove the battery while the computer is in **Standby** mode.

## Setting up your computer with Sony Notebook Setup

The **Sony Notebook Setup** utility allows you to consult system information, specify preferences for system behaviour, and set up password protection for your VAIO computer.

To use Sony Notebook Setup, proceed as follows:

- 1 Click the **Start** button on the **Windows** taskbar.
- 2 In **All Programs**, select **Sony Notebook Setup** and then click **Sony Notebook Setup**.  
The **Sony Notebook Setup** window appears.

<i>Tab</i>	<i>Description</i>
About This Computer	Displays system information, including memory capacity, serial number, and BIOS version.
Initial Setting	Selects the drive and device order you wish to use for loading the operating system. You can specify the hard drive as well as other drives inserted into your computer. You can change the volume of the sounds played while the operating system is loading.
Device	Disables ports or devices to release resources to the system. To change the port settings, select a port and click <b>Settings</b> in the <b>Device</b> tab.
S Buttons	You can link an action that you often perform to the <b>S1</b> button (button next to the power button). In <b>Sony Notebook Setup</b> there are some pre-defined actions: <b>Standby</b> , <b>Hibernate</b> , <b>External Display</b> , <b>Launch Application</b> .
Plug and Display	By default, when you connect your computer to an external display, the external display is automatically detected and Hotkey Utility automatically outputs to this display. If you want to disable this function or change the settings, you can do so on this tab.
Automatic Brightness	By default, the light sensor senses the brightness from outside and the display brightness is adjusted accordingly. This setting only applies when the display is set to automatic brightness mode. Press the <b>brightness</b> button to set the display to automatic brightness mode. You can adjust the general level of the automatic brightness mode in this tab. There are 3 possibilities: <b>Brightest</b> , <b>Standard</b> and <b>Darkest</b> .

<i>Tab</i>	<i>Description</i>
Docking Station/Port replicator (depending on your model)	You can select if you want the digital and/or analogue output to the speaker and the optical out on the docking station/port replicator.
Bass boost	Turns the <b>Bass Boost</b> function on/off (only with headphones). You can also check the effect of the <b>Bass Boost</b> function by selecting a sound file sample and playing it.
S1 button	Sets the function from a drop-down list for the S1 button located next to the keyboard. Select <b>External Display</b> and click <b>Advanced</b> to set up the display options.

3 Select the tab for the item you want to change.

4 Once finished, click **OK**.  
The settings are now in place.

 For more information about each option, click **Help** on the **Sony Notebook Setup** screen to display the help file.

If you open **Sony Notebook Setup** as a limited user, then only the **About This Computer** tab will be visible.



## Shutting down your computer safely

It is important that you shut down your computer properly so you do not lose unsaved data.

To shut down your computer, proceed as follows:

- 1 Turn off any peripherals connected to your computer.
- 2 Click the **Start** button.
- 3 Click **Turn Off Computer**.  
The **Turn off computer** window appears.
- 4 Click **Turn Off**.
- 5 Respond to any prompts warning you to save documents or to consider other users and wait for your computer to turn off automatically.  
The power indicator turns off.

 See the printed **Guide to Troubleshooting and Recovering your System** if you have problems shutting down your computer.

## Using the keyboard

Your keyboard is very similar to a standard computer keyboard, but has additional keys that perform specific notebook-related tasks.

For more information on the standard keys, please go to **Windows Help and Support Center > Start > Help and Support**. The VAIO-Link website ([www.vaio-link.com](http://www.vaio-link.com)) also contains glossary information to help you use the keyboard.

### Combinations and functions with the <Fn> key

<i>Combinations/Feature</i>	<i>Functions</i>
<Fn> + <Esc> : Standby	Puts the system into <b>Standby</b> mode, a power management state. To return the system to the active state, press any key.
<Fn> + (F5): brightness control (down)	Decreases the lightness intensity.
<Fn> + (F6): brightness control (up)	Increases the lightness intensity.
<Fn> + (F7)*: switch to the external display	Toggles between the LCD, external screen (or TV depending on which device is connected) and both LCD and external device. This function can only be used by the first user to log in. It will not work under a second user account. Toggles between LCD, external device, and both LCD and external device when a DVD is in the optical drive.
<Fn> + (F12): Hibernate	Provides for the lowest level of power consumption. When you execute this command, the states of the system and of the peripheral devices are written to the hard disk and the system power is turned off. To return the system to its original state, press the power button for one second to turn on the power. For details on power management, see the section <b>Using power saving modes (page 60)</b> .
<Fn> + <E>	Opens the disc tray.

! \* This function can only be used by the first user to log on. It will not work if you have switched to another user account. If another user wants to display on an external monitor or TV, use the monitor properties to switch to an external monitor or TV.



 These functions are not available until Windows is launched.





## *Troubleshooting sound*

### *My speakers are not producing sound*

- ❑ The built in speakers may be turned off. Press the **Mute** button at the front right of your computer to turn on the speakers.
- ❑ The speaker volume may be turned down low. Press the **Volume up** button to increase the volume.
- ❑ If your computer is powered by battery, check that the battery is inserted properly and that it is charged.
- ❑ If you are using an application that has its own volume control, check that the volume is turned up.
- ❑ Check the volume controls in Windows.

## Indicators

<i>Indicator</i>	<i>Functions</i>
Power 	<b>Power on:</b> lights green. <b>Standby mode:</b> flashes amber.
Battery 	Indicates the status of the battery.
Wireless LAN	Turns on when the Wireless LAN is activated. Turns off when the Wireless LAN is not activated.
Bluetooth indicator (depending on your model)	Turns blue when the Bluetooth functionality is available.
Memory Stick PRO	Turns on when the u is in use. Turns off when the <b>Memory Stick</b> is no longer in use.
S1 indicator	Set up a function for this button.

<i>Light</i>	<i>On</i>	<i>Off</i>
Hard disk 	Data is read from or written to the hard drive.	The hard drive is not being accessed.
Num Lock 	Turns on when the number keys in the numeric keypad are active.	Turns off when the alphanumeric character keys in the keypad area are active.
Caps Lock 	Turns on when the letters appear in uppercase as you type. The <Shift> key lowers the case of typed characters when <b>Caps Lock</b> is on.	Turns off when the letters appear in lowercase as you type (unless you hold down the <Shift> key).
Scroll Lock 	Turns on when the screen scrolls differently (not all applications support this function).	Turns off when the information moves across the screen normally.

## Using the touchpad

The keyboard features a touchpad (1), which controls the cursor on the screen. You can point to, select, drag, and scroll objects on the screen using the built-in touchpad.

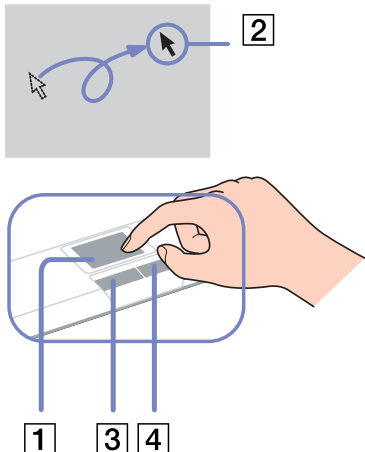

<i>Action</i>	<i>Description</i>
Point	Slide one finger on the touchpad to place the pointer (2) on an item or object.
Click	Press the left button (3) once.
Double-click	Press the left button twice.
Right-click	Press the right button (4) once. In many applications, this action displays a shortcut menu.
Drag and select	Slide one finger while pressing the left button.
Scroll	Move your finger along the right edge of the touchpad to scroll vertically. Move your finger along the bottom to scroll horizontally (the scroll function is available only with applications that support a touchpad scroll feature).

## Using the TV function

Your VAIO is equipped with a TV tuner board. The special docking station delivered with certain models\* features a TV tuner board. In combination with Sony's **VAIO Zone** software, it allows you to:

- Watch, record and play back analogue broadcasted cable and terrestrial TV programmes, all by remote control;
- Digitise analogue video and audio using the S-video or composite and audio inputs;
- Manage your video units (capsules), preview them and create multiple folders;
- Set up a timer to record channels at a repeated time;
- Suspend viewing TV (time-shifting);
- Stream your recorded TV contents via Ethernet (or WLAN) to connected PCs.

 Sony cannot guarantee the streaming of recorded content if it is beyond a certain level of high quality.

For details on using **VAIO Zone** and the remote control, please see the dedicated guide. Otherwise read the help files within the software itself.

tvTV takes your VAIO's TV functions to a new level. Never miss your favourite TV programme again, by remote-recording it via the internet onto your TV tuner-equipped VAIO. The tvTV Interactive Programme Guide gives you a comprehensive overview of what's on when and automatically synchronises it with your VAIO, wherever you happen to be at the time. For more information, read the **Welcome to TVTV** HTML files on your computer.

\* Depending on your model. Read the printed **Specifications** document for more information.

## Using the mouse

Depending on your model, your computer is delivered with a wireless optical mouse\*, which has no cables to plug in and uses a light-emitting diode (LED) instead of a ball. You can use the mouse anywhere you feel comfortable within a range of approx. 80 cm\*\* of the main unit. Avoid using the mouse on a piece of glass or other transparent material, as this can interfere with smooth cursor movement on the screen.

\* Please refer to the printed **Specifications** sheet to see whether your model is equipped with a wireless mouse.

\*\* Effective usage distance depending on the environment.

1	Left button	Click or double-click the left button to select items. To drag and drop items, hold the left button down while sliding the mouse, then release the button to drop the item.
2	Central wheel	Turn the central wheel to scroll up or down a page. Press the wheel once to lock the scroll action and control the movement by moving the entire mouse (The scroll function is available only with applications that support it).
3	Right button	Press the right button once to display a context-sensitive shortcut menu (not always an active function).
4	Power switch	Slide switch to turn the mouse on and off. This will help you save battery power.
5	<b>CONNECT</b> button	Press to enable communication between your VAIO computer and the wireless mouse.

You can adjust the mouse pointer speed and other functions under **Mouse Properties**. To display **Mouse Properties**, go to the **Control Panel**, select **Printers and Other Hardware**, then select **Mouse**.

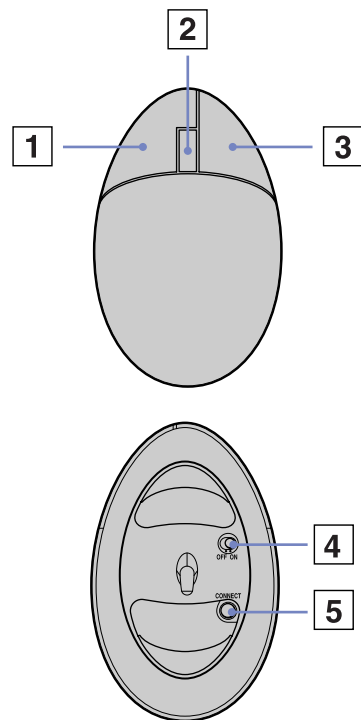

## Before you use the mouse

Before attempting to use the wireless mouse, you must enable communication between the computer and the mouse.

Two AA batteries, specific for use in the wireless mouse, are supplied with your VAIO. They are identified by a sticker "For mouse" on the packaging.

To connect the wireless mouse, proceed as follows:

- 1 Insert the two specific AA batteries into the wireless mouse as shown.

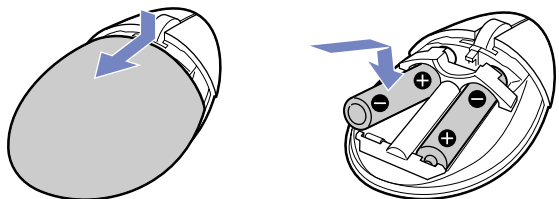

- 2 Turn on the computer.
- 3 Press the **CONNECT** button (1) on the computer.

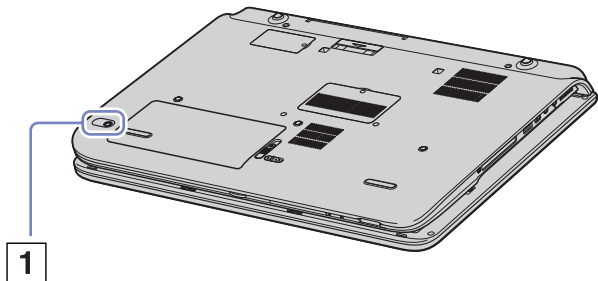



- 4 Turn the wireless mouse over, slide the power button to the **ON** position and press the **CONNECT** button.

Communication between the wireless mouse and the computer is now active.

 Steps 3 and 4 must be carried out within 10 seconds of each other.

If your wireless mouse does not operate properly, the batteries may need to be replaced. If your wireless mouse is not being used for an extended period of time, remove the batteries to avoid possible damage from battery leakage.

## Mouse information

You can check your mouse's battery power level by clicking  (**Wireless Mouse** icon), located on the Windows taskbar.

## Setting up the mouse for left-handed users

To set your mouse up for left-handed users, proceed as follows:

- 1 Go to **Start**, select **Control Panel**, then click the **Printers and Other Hardware** option.
- 2 Click the mouse icon.  
The **Mouse Properties** dialog box appears.
- 3 In the **Buttons** tab, select the option button next to **Switch primary and secondary buttons**.
- 4 Click **OK**.  
The new mouse settings are now in place.

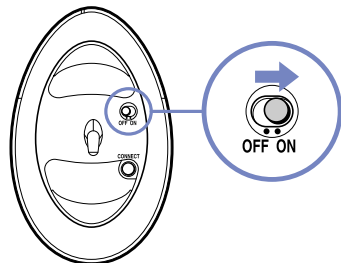

## Using special buttons

Your computer is provided with special buttons to help you use the computer by way of shortcuts.

- ❑ **Mute** button :

Turn off/on the volume by pressing the **Mute** button. The LED turns on when muted.

- ❑ **Volume** buttons (**Volume up** and **Volume down**) :

You can increase and decrease the volume.

- ❑ **Brightness** button :

You can increase and decrease the brightness intensity. When the screen is on maximum brightness intensity, the LED turns on.

### Luminous sensor:

By default, the light sensor detects the brightness from outside and the display brightness is adjusted accordingly. This setting only applies when the display is set to automatic brightness mode in **Sony Notebook Setup**. Press the brightness button to set the display to automatic brightness mode. You can adjust the general level of the automatic brightness mode in **Setting up your computer with Sony Notebook Setup (page 22)**.

- ❑ **Magnify** button (Zoom) :

You can change the image resolution in all applications, except in those that use the DVD player.

-  When an external display is connected to your computer, the **Magnify** button is disabled.

The default resolution of your computer's LCD is 1280 x 768 pixels, Highest (32 bit), and a resolution of 1024 x 600 pixels is applied after magnification.

The magnified view is implemented by applying the resolution of 1024 x 600 pixels to the LCD with the resolution of 1280 x 768 pixels, thus not as clear as the original view.

Pressing the **Magnify** button changes the resolution, which may affect software you are using that does not support a change in resolution. Make sure you quit such software before pressing the **Magnify** button.

The **Magnify** button may not work with graphic images as it magnifies the screen view by changing the resolution.

The location and size of software windows may change when the screen view is magnified or the original view is restored because pressing the **Magnify** button changes the resolution.

When the LCD screen view is magnified, switching the view to the external display disables the function and restores the original view.

- ❑ **S1** button :  
You can use this shortcut button for your favourite actions. See **Setting up your computer with Sony Notebook Setup** ([page 22](#)).

## Using the disc drive

Your computer is equipped with a double layer DVD±RW drive, which reads data from a compatible CD or DVD and writes data to a DVD-RW, DVD+RW, DVD-R, DVD+R, CD-RW, or CD-R.

To insert a disc, proceed as follows:

- 1 Turn on the computer.
- 2 Press the eject button (1) to open the drive.  
The tray slides out.
- 3 Place a disc in the middle of the tray with the label side facing up until the disc clicks into place.
- 4 Close the tray by pushing it gently.

 See the printed **Guide to Troubleshooting and Recovering your VAIO System** and the **VAIO Troubleshooting - Burning DVDs and CDs** in the **Windows Help and Support Center** if you have problems using discs.

You find the eject button on the left of the optical drive. See the **Specifications** sheet for details on your model.

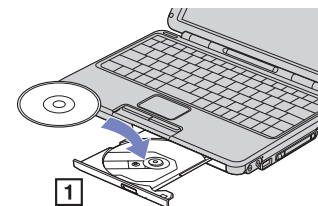
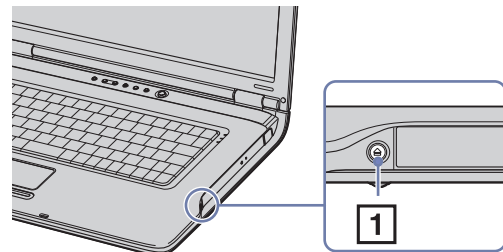

## Reading and writing CDs and DVDs

To achieve optimum performance when writing data on to disc (also called 'burning'), follow these recommendations:

- ❑ To make the data on a disc readable on an optical drive, you need to close the burning software when you eject it. To complete this process, follow the instructions included with your software.
- ❑ Only use circular discs. Do not use discs with any other shape (star, heart, card, etc.), as this may damage the disc drive.
- ❑ Do not strike or shake the computer while writing data to a disc.
- ❑ For optimal writing speed, deactivate the screensaver before writing data to a disc.
- ❑ Memory-resident disc utilities may cause unstable operation or data loss. Deactivate these utilities before writing data to a disc.
- ❑ When using your software application to burn discs, make sure you exit and close all other applications.
- ❑ Never touch the surface of the disc. Fingerprints and dust on the surface of a disc may cause writing errors.
- ❑ Do not put your VAIO computer into a power saving mode while using the pre-installed software or while using the CD burning software.
- ❑ Never put stickers on discs. This will affect the use of the disc irreparably.

 Ultra-speed CD-RW is not supported.

Supports 8cm disc reading, but does not support 8cm disc writing.

## Playing DVDs

To achieve optimum performance when playing DVDs, you should follow these recommendations.

- Play DVDs using the optical drive and the **WinDVD for VAIO** or the **VAIO Zone** software. See the help file on the **WinDVD for VAIO** software for details.
- Close all open applications before playing a DVD movie.
- Do not use resident disc utilities or resident utilities to speed up discs, because they may cause the system to become unstable.
- Make sure the screensaver is deactivated.
- Region codes indicators are labelled on the DVDs to indicate in which region and on what type of player you can play the disc. Unless a '2' (Europe belongs to region '2') or 'all' (this means that you can play this DVD everywhere in the world) is labelled on your DVD disc or on the packaging, you cannot play the disc on this player.
- Do not try to change the region code settings of the DVD drive. Any difficulties caused by changing the region code settings of the DVD drive are out of warranty.
- If your computer has Wireless LAN and Wireless LAN is activated, playing DVDs may cause some interruptions in audio and video playback.

## Troubleshooting discs

If you have problems with discs, check the printed **Guide to Troubleshooting and Recovering your VAIO System** and the VAIO-Link website ([www.vaio-link.com](http://www.vaio-link.com)).

### *My disc drive tray does not open*

If the eject button does not work try the following:

- Click **Start**, and select **My Computer**. Right-click the optical disc drive and select 'If the eject button does not work try the following.
- Make sure the computer is not in **Standby** or **Hibernate** mode.
- If this does not work, try the following:  
When the computer is OFF, open the tray by inserting a sharp, pointed object (for example a paperclip) into the hole next to the eject button.

### *I cannot play a disc*

- After inserting the disc, wait for a few seconds for the system to detect it before you try to access it.
- Make sure the label of the disc is facing up.
- If the disc requires software, make sure the software is installed according to the instructions of the program.
- Check the volume of your speakers.
- Clean the disc with an appropriate cleaner.
- Make sure your computer is running on AC power supply only and try the disc again.
- There may be condensation in the drive. Remove the disc and leave the drive open for approximately one hour. Remove the battery while you wait for the condensation to disappear.

## *I cannot play a DVD*

- ❑ If a region code warning appears when you are using the DVD player, it could be that the DVD you are trying to play is incompatible with the DVD drive on your computer. The region code is listed on the packaging of the disc.
- ❑ Change the resolution under **Control Panel - Display** to a lower resolution.
- ❑ If you see video but cannot hear sound, check all of the following:
  - ❑ Make sure the mute setting is off on your DVD player.
  - ❑ Check the **Master Volume** settings of the **Sounds and Audio Device Properties**.
  - ❑ If you have connected speakers externally, check the volume settings of your computer speakers and check the connections between your speakers and the computer.
  - ❑ In the **Device Manager**, check that the correct drivers are installed properly. To display the **Device Manager**, click **Start**, then **Control Panel**. Click **Performance and Maintenance**. Then click the **System** icon. On the **Hardware** tab, click the **Device Manager** button.
- ❑ A dirty or damaged disc may cause the computer to 'hang' while it tries to read the disc. If necessary, reboot the computer, remove the disc and then check that it is not dirty or damaged.
- ❑ Check your PG settings (Parental Guidance) in the DVD software as they might be preventing you from playing certain DVDs when they are activated.
-  On your computer, the default DVD region code is 2. Do not change this setting using the **Region Code Change** function in Windows, or using any other software applications. System malfunctions originating from the user changing the DVD region code are beyond the scope of your warranty and will result in service charges for repair.  
If you do not immediately see the **Display** icon after clicking **Control Panel**, click **Switch to Classic View** on the left.



### *I cannot play a DVD when using two screens*

- ❑ You will not have a problem in the following situations:
  - ❑ When you use a CRT or an LCD display on its own.
  - ❑ When you play MPEG files which are recorded on the hard drive with Windows Media Player 9.

### The reading speed of CD/DVD-RWs is very slow

Generally, the reading speed of a CD/DVD-RW is slower than that of a -ROM or -R. The reading speed can also vary depending on the type of format.

### *The disc tray ejects even when it has been locked into place*

- ❑ Ensure that the disc is placed with the label side facing up.
- ❑ Clean the disc and the disc drive lens with an appropriate cleaner.
- ❑ The disc may be scratched. Place another disc to see if that is the reason.
- ❑ There may be condensation in the drive. Remove the disc and leave the drive open for approximately one hour. Remove the battery while you wait for the condensation to disappear.

## Using PC Cards

Your computer features a PC Card slot that supports Type I or Type II PC Cards. PC Cards allow you to connect portable external devices.

### Inserting a PC Card

You do not need to shut down your computer when inserting a PC Card.

To insert a PC Card, proceed as follows:

- 1 Insert the PC Card into the PC Card slot with the front label and arrow facing upwards.

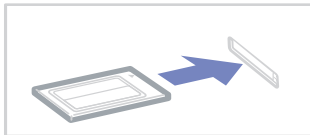

- 2 Gently push the PC Card slot into the connector.  
The PC Card is automatically detected by your system.  
The **Safely Remove Hardware** icon  appears in the system tray.

 Some devices may not function properly if you repeat returning to **Normal** mode from **Standby** mode or **Hibernate** mode.

The computer will return to its original state if you restart it.

Make sure you use the most recent software driver provided by the PC Card manufacturer.

If an “!” mark appears on the **Device Manager** tab in the **System Properties** dialog box, remove the software driver and then reinstall it.

You do not need to shut down the computer before inserting or removing a PC Card.

Do not force a PC Card into the slot as it may damage the connector pins. If you have difficulty inserting a PC Card, check that you are inserting the PC Card in the correct direction. See the manual supplied with your PC Card for more information on use.

Do not carry your computer while touching the head of a PC Card, as pressure or shock may damage the connector pins.

While the card is inserted, your computer may not enter the **Hibernate** power management mode. It may enter **Standby** mode. It is recommended that you remove the card before your computer enters **Hibernate** mode by pressing the **<Fn>+<F12>** keys, and when it is set to enter **Hibernate** automatically while using a battery as the source of power.

## Removing a PC Card

Follow the steps below to remove the PC Card while your computer is on. If it is not removed in the correct way, your system may not work properly. If you want to remove a PC Card when your computer is off, skip steps 1 to 7.

To remove a PC Card, proceed as follows:

- 1 Double-click the **Safely Remove Hardware** icon  in the system tray. The **Safely Remove Hardware** dialog box appears.
- 2 Select the hardware you want to unplug.
- 3 Click **Stop** and confirm that the device can be safely removed from the system.
- 4 Click **OK**.  
A dialog box appears, explaining that it is safe to remove the device.
- 5 Click **OK** and **Close**.
- 6 Push the PC Card release button so that the release button pops out.
- 7 Push the PC Card release button a second time so that the PC Card ejects.
- 8 Gently take hold of the card and pull it out of the slot.

 If you unplug the PC Card from the computer when it is still turned on, your system might crash and you might lose data that you did not save before.

Before you remove the PC Card, click the PC Card icon in the taskbar and close the card. Close any applications that use the PC Card before removing the card. Otherwise, data may be lost.

## *Troubleshooting PC Card*

### *My PC Card is not working*

- Make sure the PC Card is compatible with your version of Windows.
- Use the **Sony Notebook Setup** utility to disable devices you are not currently using.

## Using the Memory Stick

Your VAIO computer is designed to support the Memory Stick. The Memory Stick is a compact, portable, and versatile device especially designed for exchanging and sharing digital data with compatible products, such as digital cameras, mobile phones and CLIÉ handheld devices. Because it is removable, it can be used for external data storage.

Use the flash memory technology to download anything that can be converted into digital data, such as pictures, music, words, sounds, movies and photographs. The Memory Stick family ranges in capacity and compatibility.

Please see your printed **Specifications** sheet to see which Memory Stick types are compatible with your VAIO and if there are any limitations.

- ❑ You can purchase Memory Sticks from the Sony Style website ([www.sonystyle-europe.com](http://www.sonystyle-europe.com)), or from your local Sony dealer.
- ❑ Detailed information about which CLIÉ handhelds are compatible with which Memory Sticks can be found here: [www.clie-link.com](http://www.clie-link.com).
- ❑ Detailed information about which VAIO computers are compatible with which Memory Sticks can be found here: [www.vaio-link.com](http://www.vaio-link.com).

## Write-protecting a Memory Stick

Some Memory Sticks are designed with an erasure prevention switch to protect valuable data from accidental erasure or overwriting. Move the tab horizontally or vertically to set or release write-protection\*. When the erasure prevention switch is off, data can be saved on the Memory Stick. When the erasure prevention switch is on, data can be read from but not saved on the Memory Stick.

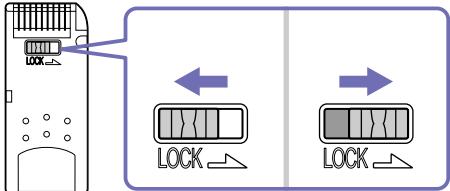

\* Some kinds of Memory Stick do not have a lock switch.

## Inserting a Memory Stick

To insert a Memory Stick, proceed as follows:

- 1 Once you have stored your data from your digital device, insert the Memory Stick with the arrow facing up and toward the Memory Stick slot.
  - 2 Carefully slide the Memory Stick into the slot until it clicks in place.  
The Memory Stick is automatically detected by your system and appears in your **My Computer** window as a local drive.
- ! Hold the Memory Stick with the arrow pointing in the correct direction when you insert it into the slot. To avoid damaging the computer or the Memory Stick, do not force the Memory Stick into the slot if it does not insert smoothly.

 This model supports Memory Stick DUO. For more information on Memory Stick DUO, please visit [www.memorystick.com](http://www.memorystick.com) website.

Loading large volumes, for example, image clips, may take a while.

## Removing a Memory Stick

To remove a Memory Stick, proceed as follows:

- 1 Check that the access light is off.
  - 2 Push the Memory Stick in towards the computer.  
The Memory Stick ejects.
  - 3 Pull the Memory Stick out of the slot.
-  Always remove the Memory Stick gently, or it may pop out unexpectedly.

It is recommended that you remove the Memory Stick before shutting down the computer.

Do not remove the Memory Stick while the Memory Stick indicator is turned on. If you do, you may lose data.

## Using the modem

Your computer is equipped with an internal modem. You need to connect to a phone line to take advantage of online services and the internet, as well as to register your computer and software online, and to contact VAIO-Link by e-mail.

Use the single RJ-11 jack to connect the supplied modem cable to the phone line.

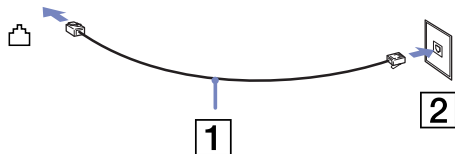

## Troubleshooting the modem

If you have problems with your modem, check the printed **Guide to Troubleshooting and Recovering your VAIO System** and the VAIO-Link website ([www.vaio-link.com](http://www.vaio-link.com)).



## Using the Bluetooth functionality

If your notebook is equipped with the Bluetooth functionality\*, you can establish wireless communication between your notebook and other Bluetooth devices such as another notebook, a mobile phone or a modem station. You can transfer data between these devices without cables and up to 10 metres range in open space.

To connect to a Bluetooth device, proceed as follows:

- 1 Turn on the Wireless switch on the front of your notebook.  
The **Switch wireless devices** dialog box appears.
- 2 Select the **Bluetooth** option.
- 3 Click **OK**.

\*Read the printed **Specifications** document for more information.

 Read the **Regulations Guide** before using the Bluetooth functionality.

The 2.4 GHz band with which Bluetooth devices or wireless LAN devices work, is used by various devices. Bluetooth devices use the technology to minimize the interference from other devices that use the same wave length. Communication speed and distances can be inferior to the standard values. Interference from other devices may also stop communications. Do not simultaneously use the Bluetooth function and wireless communication devices which use the 2.4 GHz band, such as a wireless LAN PC Card.

! The Bluetooth functions may not work depending on the third party devices or the software version used by third party companies.

! When you purchase Bluetooth devices, check their operating conditions.

## Bluetooth security

The Bluetooth wireless technology has an authentication function, which allows you to control with whom you communicate. With the authentication function, you can avoid any anonymous Bluetooth devices accessing your notebook.

The first time two Bluetooth devices communicate, a common **Passkey** (a password required for authentication) should be determined for both devices to be registered. Once a device is registered, there is no need to reenter the **Passkey**.

You can change your settings in order not to be discovered by other Bluetooth devices or you can set a limit.

## *Communicating with another Bluetooth device*

You can transfer data to and from other Bluetooth devices such as another notebook, a mobile phone or a modem station without using cables.

To communicate with another Bluetooth device, proceed as follows:

- 1 Turn on the Wireless switch.
- 2 Choose **Start > Control Panel > Network and Internet Connections > Bluetooth Devices**.  
The **Bluetooth Device** dialog appears.
- 3 Click **Add**.  
The **Add Bluetooth Device Wizard** appears.
- 4 Select the check box **My device is set up and ready to be found** and then click **Next**.
- 5 Select the remote device you want to connect to. If necessary, scroll up and down in the **Bluetooth Device List** to make your selection. Then click **Next**.

6 Choose one of the following options:

- If you want Windows to provide you with a password, select **Choose a Passkey for me.**
- If the documentation of the other Bluetooth device contains a password, click **Use the passkey found in the documentation** and enter the passkey.
- If you want to create your own password, click **Let me use my own passkey** and enter a passkey.
- If your device does not use a password, click **Don't use a passkey.**

7 Click **Next** to continue.

8 Once the remote device has been successfully authenticated, click **Finish.**

 The passkey can be different each time, but must be the same at both ends.

For certain devices, such as a mouse, no passkey can be entered.



## *Communicating with another Bluetooth device using Bluetooth File Transfer Wizard*

You can easily transfer data, such as files or pictures, to another Bluetooth device.

To transfer data from or to another Bluetooth device, proceed as follows:

- 1 Choose **Start > All Programs > Accessories > Communications > Bluetooth File Transfer Wizard**.  
The **Bluetooth File Transfer Wizard** appears.
- 2 Click **Next** to continue.
- 3 Follow the steps in the **Bluetooth File Transfer Wizard** to communicate with another Bluetooth device.

## *Stopping the Bluetooth connection*

To stop the Bluetooth connection, turn off the Wireless switch at the front of your notebook. The Bluetooth LED turns off.

## *Troubleshooting Bluetooth*

### *I cannot use the Bluetooth functions*

- If the Bluetooth LED is off, turn on the Wireless switch.
- You cannot use the Bluetooth function when the computer is in a power saving mode. Return to normal mode, then turn on the Wireless switch located on your notebook.

### *I cannot find the Bluetooth device with which I want to communicate*

- ❑ If the connected device is also connected to other devices, it may not appear on the **Devices** tab in the in your **Remote Bluetooth Device Panel** dialog or you may not be able to communicate with the device.
- ❑ Check that the Bluetooth function of the device with which you want to communicate is on. See the other device's manual for more details.
- ❑ If the device with which you want to communicate is already communicating with another Bluetooth device, it may not be found or it may not be able to communicate with your notebook.
- ❑ To allow other Bluetooth devices to communicate with your notebook, go to the **Options** tab in the **Bluetooth Device** dialog box and select the checkbox **Allow Bluetooth devices to connect to this computer**.  
For more information on the the **Bluetooth Device** dialog box, see **Communicating with another Bluetooth device** ([page 49](#)).

### *The data transfer speed is slow*

The data transfer speed depends on the obstacles and/or the distance between the two devices, but also on the radio wave quality, the operating system and the software used. Try to move your notebook or try to place the two devices closer together.

### *I cannot communicate with the other device although the distance between both devices is within 10 metres*

- ❑ The data transfer distance can be shorter than 10 metres depending on existing obstacles between the two devices, on radio wave quality, on the operating system and the software used. Try moving your notebook or placing both devices closer together.
- ❑ If the device with which you want to communicate is already communicating with another Bluetooth device, it may not be found or it may not be able to communicate with your notebook.
- ❑ Check that the Bluetooth function of the device with which you want to communicate is on. See the other device's manual for more details.

## Using Wireless LAN (WLAN)

Thanks to Sony's Wireless LAN (WLAN)\*, all your digital devices with built-in WLAN functionality communicate freely with each other through a powerful network. A WLAN is a network in which a mobile user can connect to a local area network (LAN) through a wireless (radio) connection. So there is no need anymore to pull cables or wires through walls and ceilings.

The Sony WLAN supports all normal Ethernet activities, but with the added benefits of mobility and roaming. You can still access information, internet/intranet and network resources, even in the middle of a meeting, or as you move from one place to another. You can communicate **without an Access Point**, this means that you can communicate between a limited number of computers (**computer-to-computer**), or you can communicate **with an Access Point**, which allows you to create a full infrastructure network (**infrastructure**).

\* Depending on your model.

 In some countries, using WLAN products may be restricted by the local regulations (e.g. limited number of channels). Therefore, before activating the WLAN functionality, read the **Regulations Guide** carefully. Channel selection is explained further in this manual (see **How to select a Wireless LAN channel** ([page 57](#))).

WLAN uses the IEEE 802.11b/g standard, which specifies the used technology. The standard includes the encryption method: **Wired Equivalent Privacy (WEP)**, which is a security protocol and **WiFi Protected Access (WPA - Proposed jointly by the IEEE and Wi-Fi Alliance, WiFi Protected Access is a specification of standards based, interoperable security enhancements that increase the level of data protection and access control for existing WiFi networks. WPA has been designed to be forward compatible with the IEEE 802.11i specification. It utilizes the enhanced data encryption TKIP (Temporal Key Integrity Protocol) in addition to user authentication using 802.1X and EAP (Extensible Authentication Protocol)). Data encryption protects the vulnerable wireless link between clients and Access Points. Besides that, there are other typical LAN security mechanisms to ensure privacy, such as: password protection, end-to-end encryption, virtual private networks, and authentication.**

Wireless LAN devices using the IEEE 802.11a standard and those using the IEEE 802.11b or g standard cannot communicate because the frequencies are different. Wireless LAN devices using the IEEE 802.11g standard can only communicate with a device using the IEEE 802.11b standard, not with the a standard.

IEEE 802.11b: The standard speed is 11 Mbps, or about 30 to 100 times faster than a standard dial up.

IEEE 802.11g: The standard speed is 54 Mbps, or about 5 times faster than a Wireless LAN device using the IEEE 802.11b standard.

## *Communicating without an Access Point (computer-to-computer)*

A computer-to-computer network is a network in which a local network is created only by the wireless devices themselves, with no other central controller or Access Point. Each device communicates directly with other devices in the network. You can set up a computer-to-computer network easily at home.

To communicate without an Access Point (computer-to-computer), proceed as follows:

- 1 Turn on the wireless switch.  
If your computer supports Bluetooth, the **Wireless Device Switch** dialog box appears.  
Select the **Enable 2.4 GHz Wireless LAN** check box and deselect the **Enable Bluetooth Device** check box, then click the **OK** button.  
The Wireless LAN indicator lights up.
- 2 Right-click the network icon in the taskbar displaying **Wireless Network Connection**.
- 3 Click **View Available Wireless Networks**.  
The **Wireless Network Connection** dialog box appears.
- 4 Click the **Change advanced settings** link.  
The **Wireless Network Connection Properties** dialog box appears.
- 5 Select the **Wireless Networks** tab.
- 6 Click the **Add** button.  
The **Wireless network properties** dialog box appears.
- 7 Enter a **Network name (SSID)\***.
- 8 Select **Open** from the **Network Authentication** drop-down box.
- 9 Select **WEP** from the **Data Encryption** drop-down box if you want to use data encryption.
- 10 Deselect the **The key is provided for me automatically** option button.  
Some information becomes visible.
- 11 Fill in the **Network key\***.

- 12 Fill in exactly the same **Network key** again, for confirmation.
- 13 Select the **This is a computer (ad hoc) network; wireless access points are not used** check box at the bottom of the screen.
- 14 Click **OK**.  
Your **Network name** appears in the **Preferred networks** list.
- 15 Click **OK**.  
The network you have created appears in the list.  
Your computer is ready to communicate with another computer.

\* If you want to communicate between two or more computers, you need to configure all these computers the exact same way. This means that you need to enter the same Network name and the same Network key on all computers as on the first computer you configure.

 In France, only certain channels are legally allowed when using WLAN outdoors. For more information, see the **Regulations Guide**.

A computer-to-computer network does not support WPA.

A Network key can contain ASCII or hexadecimal characters:

**ASCII:** The basis of character sets used in almost all present-day computers. ASCII is a code for representing English characters as numbers, with each letter assigned a number from 0 to 127.

**Hexadecimal:** A number representation using the digits 0-9, with their usual meaning, plus the letters A-F (or a-f) to represent hexadecimal digits with values of (decimal) 10 to 15.



## Communicating with an Access Point (infrastructure)

An infrastructure network is a network that extends an existing wired local network to wireless devices by providing an Access Point, for example the **Sony PCWA-A320 Access Point**. The Access Point bridges the wireless and wired LAN and acts as a central controller for the Wireless LAN. The Access Point coordinates transmission and reception from multiple wireless devices within a specific range.

To communicate with an Access Point (infrastructure), proceed as follows:

- 1 Set up the Access Point as described in the manual delivered with the Access Point and turn on the Access Point.
- 2 Turn on the wireless switch.  
If your computer supports **Bluetooth**, the **Wireless Device Switch** dialog box appears.  
Select the **Enable 2.4 GHz Wireless LAN** check box and deselect the **Enable Bluetooth Device** check box, then click the **OK** button.  
The Wireless LAN indicator lights up.
- 3 Right-click the network icon in the taskbar displaying **Wireless Network Connection**.
- 4 Click **View Available Wireless Networks**.  
The **Wireless Network Connection** dialog box appears.  
The Access Points appears in the list.  
If the Access Point is not displayed, click the **Refresh network list** link.
- 5 Select the network you want to use and click the **Connect** button.  
The **Wireless Network Connection** dialog box appears.
- 6 Type the **Network key** if applicable and click the **Connect** button.  
After 30 seconds, the connection is established.  
Once you are connected, you see the word **Connected** appear behind the name of the network.



For more information about setting up an access point, see the documentation supplied with your **Access Point**.

## *How to select a Wireless LAN channel*

In an 802.11b/g configuration, channels 1 to 13 can be used.

### *(a) With an Access Point ("Infrastructure")*

- The channel used will be the channel selected by the Access Point.

 For details on how to select the channel that will be used by the Access Point, please refer to the corresponding instruction manual.

### *(b) Without Access Point ("computer-to-computer")*

- If the Wireless connection is initiated by the VAIO computer, channel 11 will be selected.
- If the Wireless connection is initiated by a peer Wireless LAN equipment, the Wireless LAN communication will make use of the channel selected by the peer Wireless LAN equipment.

 In France, outdoors, Wireless LAN connections are only allowed on certain channels. For details, please refer to the **Regulations Guide**.

## Troubleshooting Wireless LAN

if you cannot use the Wireless LAN function, make sure the wireless switch is turned on before checking the following points.

### *The Wireless LAN Access Point and my computer cannot communicate*

- Check if the power of the Access Point is turned on.
- Check if the Access Point is displayed in the **View Available Networks** list.  
(Right-click the network icon in the taskbar displaying **Wireless Network Connection**. Click the **View Available Wireless Networks** link.)  
If the Access Point is displayed, select the Access Point and click the **Connect** button.  
If the Access Point is not displayed, click the **Refresh Network List** and create a network (See **Communicating with an Access Point (infrastructure)** (page 56)).
- Connection availability is affected by distance and obstructions. You may need to move your computer away from obstructions or nearer to any Access Point you may be using.

### *The data transfer speed is slow*

- The maximum communication speed can vary depending on the obstacles or the distance between the communication devices and the radio waves. Remove the obstacle or make the distance between the Access Point and your machine smaller.
- It is possible that your Access Point communicates at the same time with another Access Point. Read the manual of the Access Point.
- If several computers communicate with the same Access Point, the concentration may be too high. Wait a few minutes and try to access it again.
- If a Wireless LAN device using the IEEE 802.11g standard communicates with a device using the IEEE 802.11b standard, it is normal that the speed is reduced. Devices using the IEEE 802.11g standard are 5 times faster than the ones using the IEEE 802.11b standard.

### *I cannot access the internet*

- ❑ Check the settings of the Access Point. See the manual of the Access Point.
- ❑ Check if your computer and the Access Point are communicating. If they are communicating, you see the word **Connected** appear behind the name of the network.

### *I cannot establish a Wireless LAN connection*

If you have problems with your Wireless LAN connection, check the printed **Guide to Troubleshooting and Recovering your VAIO System** and the VAIO-Link website ([www.vaio-link.com](http://www.vaio-link.com)).

## Using power saving modes

When you use a battery as the source of power for your computer, you can take advantage of power management settings to conserve battery life. In addition to the normal operating mode, which allows you to turn off specific devices, your computer has two distinct power saving modes: **Standby** and **Hibernate**. When using battery power, you should be aware that the computer automatically enters **Hibernate** mode when the remaining battery charge drops below 7%, regardless of the power management setting you select.

 If the battery level falls below 10%, you should either attach the AC adapter to recharge the battery or shut down your computer and insert a fully charged battery.

### Using Normal mode

This is the normal state of your computer when it is in use. The green power indicator light is on in this mode. To save power while not working, you can turn off a specific device such as the LCD or the hard disk.

### Using Standby mode

**Standby** mode turns off the LCD screen and sets the hard disk and the CPU to a low power consumption mode. The amber power light flashes in this mode.

To activate Standby mode, proceed as follows:

Go to **Start/Turn Off Computer** and press **Stand By**.

Or press the **<Fn>+<Esc>** keys simultaneously.

To return to **Normal** mode, press any key.

 If you press the power button for more than 4 seconds, the computer will switch off automatically. You will lose any unsaved data.

When the computer is in **Standby** mode, you cannot insert a disc.

The computer comes out of **Standby** mode quicker than out of **Hibernate** mode.

**Standby** uses more power than **Hibernate**.

If the battery runs down when your computer enters **Standby** mode, you will lose any unsaved data. Going back to the previous work state is impossible. To avoid loss of data, you should save your data frequently.

If the computer is not used for 25 minutes, it will enter **Standby** mode. To avoid this, you can change the settings in the **Power Options Properties** screen (right-click the **power status** icon in the taskbar - select **Adjust Power Properties** - select the **Power Schemes** tab and change the settings in **Settings for VAIO optimized power scheme**).

## Using Hibernate mode

The state of the system is saved on the hard disk and power is turned off. Even when the battery runs down, no data will be lost. The power indicator light is off in this mode.

To activate Hibernate mode, proceed as follows:

Press **<Fn>+<F12>**.

The **Hibernating** screen appears and the computer enters **Hibernate** mode.

Alternatively,

Click **Start**, and then **Turn Off Computer**.

In the **Turn off computer** screen, hold down the **<Shift>**-key and press **Hibernate**.

To return to Normal mode, proceed as follows:

Turn on the computer by pressing the power button.

The computer returns to its previous state.



If you press the power button for more than 4 seconds, the computer will switch off automatically.

If you do not use the AC adapter for a long period of time, put your computer into **Hibernate** mode. This power saving mode saves you the time of shutting down in the normal way.

When the computer is in **Hibernate** mode, you cannot insert a disc.

**Hibernate** mode requires more time than **Standby** mode to be activated.

It takes more time to return to normal mode from **Hibernate** mode than from **Standby** mode.

**Hibernate** mode uses less power than **Standby** mode.

Do not move the computer until its power indicator turns off while entering **Hibernate** mode.

## *Troubleshooting power management*

### *The power management setting is not responding*

Your computer's operating system may become unstable if a lower power state, such as **Hibernate** is initiated, and then changed before the computer completely enters the lower power state.

To restore the computer to its normal operating stability, proceed as follows:

- 1 Close all open applications.
- 2 Press **<Ctrl>+<Alt>+<Delete>** simultaneously and select **Restart** from the drop-down list.  
The computer restarts.
- 3 If the procedure does not work, press and hold the power button for 4 seconds or longer to shut down the computer.

## *Managing power with VAIO Power Management*

Power management helps you to set up power schemes of your computer running on AC power or batteries, to suit your requirements for power consumption.

VAIO Power Management is a software application developed exclusively for VAIO computers. With this software application, you can enhance the Windows power management functions to ensure that your computer performs better and the battery lasts longer.

### *Activating VAIO Power Management*

When you start the computer, a **power status** icon appears in the taskbar. This icon indicates what kind of power source you are using at that time, for example, AC power. If you double-click this icon, the **Power Meter** screen appears showing you the power status.

VAIO Power Management functionalities are added to the Windows **Power Options Properties**.



To activate anagement, proceed as follows:

- 1 Right-click the **power status** icon in the taskbar.
- 2 Select **Adjust Power Properties**.  
The **Power Options Properties** screen appears.
- 3 Select the **VAIO Power Management** tab.

### *Activating VAIO Power Management power schemes*

VAIO Power Management provides several predefined **power schemes**. Each power scheme consists of a group of power management settings that are designed to meet specific power management goals, ranging from maximum power management to no power management.

To activate a VAIO Power Management power scheme, proceed as follows:

- 1 Open **Adjust Power Properties**.
- 2 Select the **Power Schemes** tab.
- 3 Select a power scheme in the **Power schemes** drop-down list.
- 4 If you now select the **VAIO Power Management** tab, you see that the selected power scheme appears to the right of **Power Scheme**.
- 5 If necessary, you can change the items in the list, example, the brightness of the LCD.
- 6 Click **OK**.  
The power scheme has been activated.

 You need administrator rights to set up a power scheme on your computer. If you are the only user, you already have administrator rights; if not, ask your system administrator.

For more information on **VAIO Power Management** and **Power Schemes**, please read the online help file.

<i>Power Scheme</i>	<i>Description</i>
Power Management Off	Turns off all power management features such as <b>Standby</b> and <b>Hibernate</b> modes.
VAIO Optimized	The power management state when AC power is in use.
VAIO Maximum Battery	Provides power saving features to give you maximum battery life and good performance. It reduces the brightness of the display and puts the system into <b>Standby</b> mode after a specified time period.
VAIO Ultimate Battery	Extends the <b>VAIO Maximum Battery</b> by completely disabling the optical drive.

 If you have a mobile CPU (see the printed **Specifications** sheet), a CPU control icon may appear in the taskbar. The CPU control icon indicates the CPU control status (Performance, Adaptive, Battery Life, Degrade). To make the icon appear, click the **Advanced** button on the **VAIO Power Management** tab. Select the **Show CPU status icon in the taskbar** box and then click **OK**.

If you want to know more about the CPU control icon, read the online help file (**Other Information - Icons on the Notification Area**).

## Restoring the default settings

The power scheme settings that you changed on the **VAIO Power Management** tab can be restored to the default settings.

To restore the default settings, proceed as follows:

- 1 Select the **VAIO Power Management** tab in the **Power Options Properties** window.
- 2 Click **Advanced**.  
The **VAIO Power Management** window appears.
- 3 Click the **Reset by default** button.  
The **Confirm** window appears.
- 4 Select the **Restore all power schemes to the original factory default settings**.
- 5 Click **OK**.  
The **Confirm** window closes and the default settings are restored for all the power scheme options.

## VAIO Power Management Viewer

Depending on your model, VAIO Power Management Viewer is installed on your computer.

To start VAIO Power Management Viewer, proceed as follows:

Click  on the **VAIO Power Management** tab in the Windows **Power Options Properties**.

Alternatively, you can click **Start**, point to **All Programs** and **VAIO Power Management**, and then click **VAIO Power Management Viewer** to start the viewer.

VAIO Power Management Viewer is provided with two tabs: **Running on batteries** and **Plugged in**. Starting the viewer automatically displays the tab appropriate to the current power scheme of your computer. On each tab, the radar chart shows performance with the current power scheme and the modified power scheme in the designated colors.

To change the power scheme, proceed as follows:

Select the desired power scheme from the drop-down list on VAIO Power Management Viewer.

To view performance with the power scheme modified with VAIO Power Management, proceed as follows:

When both VAIO Power Management and VAIO Power Management Viewer are running, VAIO Power Management Viewer shows performance with the power scheme that was modified with VAIO Power Management.

 Use VAIO Power Management to set up or modify the power scheme.

## Connecting peripheral devices

You can add functionality to your computer by using the various ports on your unit.

- ❑ **Connecting a docking station** ([page 69](#))
- ❑ **Connecting an external display** ([page 75](#))
- ❑ **Selecting display modes** ([page 81](#))
- ❑ **Using the Dual Display function** ([page 82](#))
- ❑ **Connecting external speakers** ([page 85](#))
- ❑ **Connecting an external microphone** ([page 86](#))
- ❑ **Connecting a Universal Serial Bus (USB) device** ([page 87](#))
- ❑ **Connecting a printer** ([page 92](#))
- ❑ **Connecting an i.LINK device** ([page 94](#))
- ❑ **Connecting to a network (LAN)** ([page 97](#))

 To identify and locate the ports on your computer, please see the printed **Specifications** sheet.

Sony computer supplies, accessories and peripherals can be purchased from your local retailer or from the Sony website: [www.sonymstyle-europe.com](http://www.sonymstyle-europe.com)

For more information about connection compatibility, go to the VAIO-Link website: [www.vaio-link.com](http://www.vaio-link.com)

## Connecting a docking station

Your computer supports the use of a docking station. Attaching a docking station enables you to connect additional peripherals to your computer, such as a printer or an external display.

If your model is delivered with a docking station, it features a TV tuner board. In combination with Sony's **VAIO Zone** software, you can watch and record television programs directly on your notebook. For more information, see **Using the TV function** (page 29) or the **VAIO Zone** guide.

On this docking station, you can use the following ports to extend the features of your VAIO:

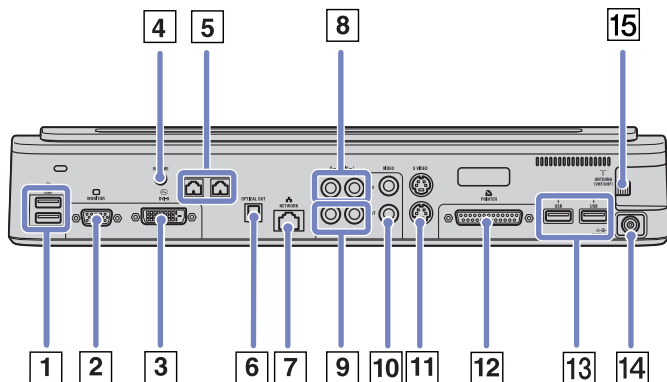

1	2 USB ports	(page 87)	5	Right/Left speaker connectors	(page 85)	9	Right/Left audio out	(page 78)	13	2 USB ports	(page 87)
2	Monitor/VGA port	(page 76)	6	Optical out	(page 78)	10	S-Video connectors	(page 78)	14	DC In	(page 17)
3	DVI-D connector	(page 76)	7	Network	(page 97)	11	Video connectors	(page 78)	15	Antenna	(page 29)
4	Speaker volume connector	(page 85)	8	Right/Left audio in	(page 78)	12	Printer port	(page 92)			

If your notebook does not come with a docking station, you can use the following optional docking station (**VGP-PRA1**):

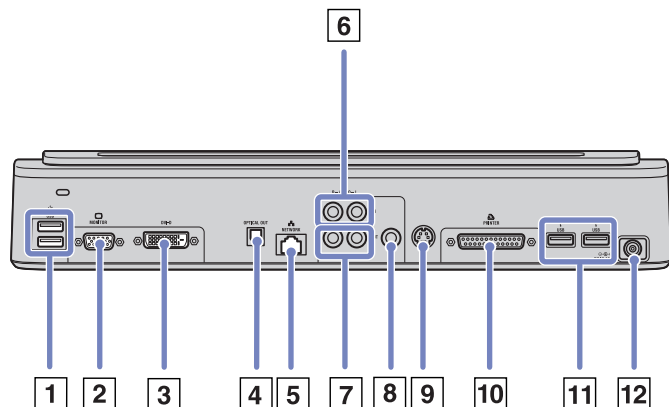

1	2 USB ports	<a href="#">(page 87)</a>	5	Network	<a href="#">(page 97)</a>	9	S-Video connector	<a href="#">(page 78)</a>
2	Monitor/VGA port	<a href="#">(page 76)</a>	6	Right/Left audio in	<a href="#">(page 85)</a>	10	Printer port	<a href="#">(page 92)</a>
3	DVI-D connector	<a href="#">(page 76)</a>	7	Right/Left audio out	<a href="#">(page 78)</a>	11	2 USB ports	<a href="#">(page 87)</a>
4	Optical out	<a href="#">(page 78)</a>	8	Video connector	<a href="#">(page 78)</a>	12	DC In	<a href="#">(page 17)</a>

 The docking station can be powered only with the AC adapter supplied with your computer. Do not remove the AC adapter from the docking station or the AC outlet when using the docking station; this may cause data damage or hardware malfunctions.

When connecting video cables to S-Video out and Video out simultaneously, only the S-Video out connector can be used.

## Attaching your computer to a docking station

To attach your computer to a docking station, proceed as follows :

- 1 Disconnect all peripherals from the computer.
- 2 Plug the cable attached to the AC adapter (1) into the DC In port (2) on the docking station (3).
- 3 Plug the power cord (4) into the AC adapter and an AC outlet.

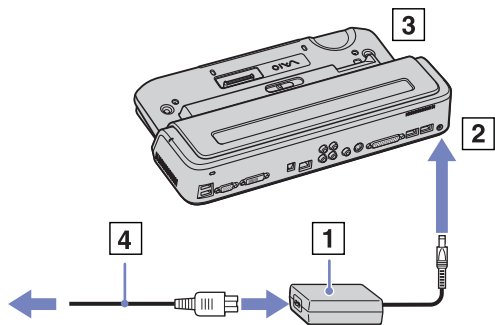

- 4 Open the docking station cover.

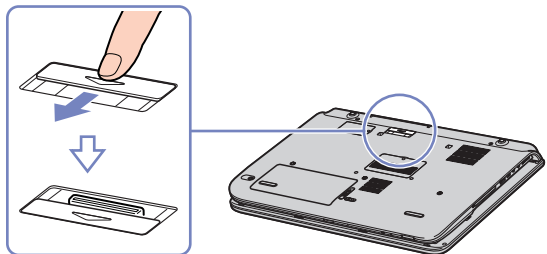



5 Slide the lock lever to **UNLOCK**.

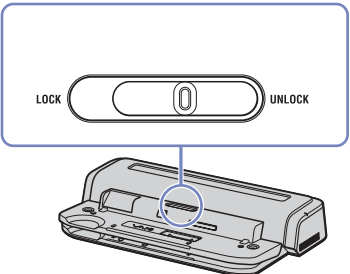

6 Align the bottom connectors of the notebook with the connectors on the docking station.

7 Push the notebook into the docking station and then push down until it clicks into place.

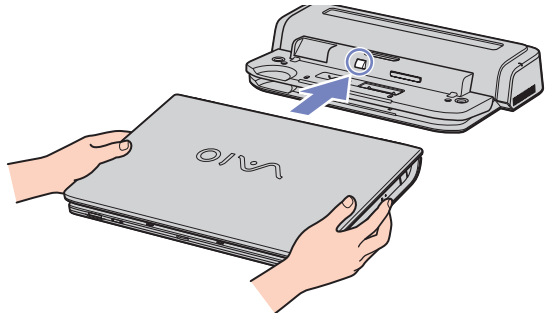

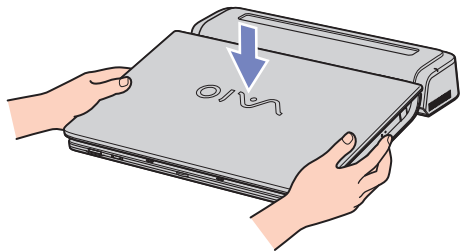

8 Slide the lock lever to **LOCK**.

9 Turn on the notebook.

 When attaching your computer to the docking station, do not attempt to insert or remove the battery pack. Lifting and turning the computer with the attached docking station may cause a temporary loss of power.

Use the AC adapter that comes with your notebook or the optional Sony adapter.

## Disconnecting your computer from the docking station

To disconnect your computer from the docking station, proceed as follows:

- 1 Disconnect all peripherals from the computer.
- 2 Slide the lock lever to **UNLOCK**.

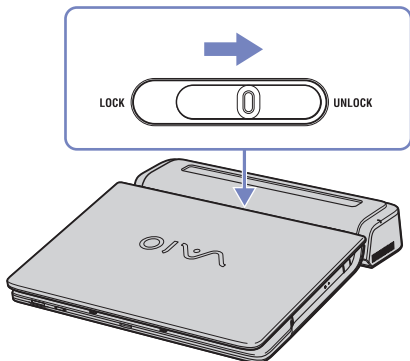

- 3 Lift the computer away from the docking station.

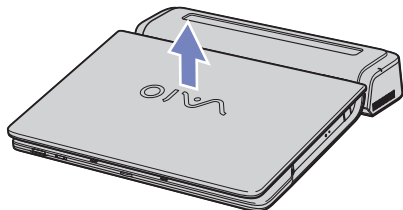

- 4 Close the docking station connector cover on the bottom of your computer.



It is extremely important to close the docking station connector cover after removing your computer from the docking station. If the cover is left open, dust may get inside and damage the computer.

To disconnect your docking station completely from the mains voltage, unplug the AC adapter.

## *Connecting an external display*

You can connect an external display to your computer. For example, you can use your notebook with a computer display or a projector, a TV or a projector.



Turn off your computer and the peripherals, unplug the AC adapter and the power cord before connecting the external display.

Connect the power cord after connecting all other cables.

Turn on the peripherals, then turn on your computer.

Connected external displays are used as secondary screens.

## Connecting a computer display

You can connect a computer display either directly to your computer or via a docking station.

To connect a computer display, proceed as follows:

- 1 If you want to connect a VGA monitor, plug the display cable (1) (not supplied) into the monitor/VGA connector (2) on the notebook or on the docking station.
- 2 If you want to connect a TFT/DVI monitor, plug the display cable (not supplied) into the DVI-D connector on the docking station.
- 3 If necessary, plug one end of the display's power cord (3) into the display, and the other end into an AC outlet.

 **DVI-D** stands for **Digital Visual Interface - Digital**. It is a 24-pin DVI connector supporting digital video signals only.

A **DVI-I** connector (**Digital Visual Interface - Integrated**) supports digital video and analogue video signals. It has 29 pins.

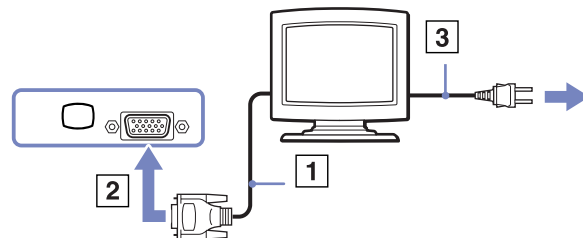

! You can not connect a DVI-I to VGA cable to a DVI-D connector.



## Connecting a multimedia computer display

You can connect the computer to a multimedia computer display that includes built-in speakers and a microphone.

To connect a multimedia computer display, proceed as follows:

- 1 Plug the display cable (1) into the monitor/VGA connector (2)  on the computer.
- 2 Plug the speaker cable (3) into the headphone connector (4)  on the computer.
- 3 Plug the microphone cable (5) into the microphone connector (6)  on the computer.

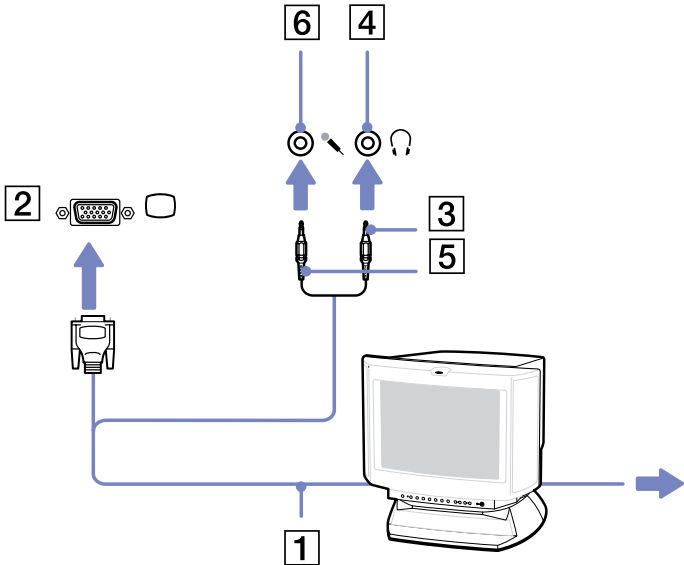

## Connecting a TV

You can connect a TV to the computer or to the optional docking station.

To connect a TV to the computer, proceed as follows:

- 1 Plug one end of the audio/video cable (1) (optional) into the TV Out connector (2) (yellow) and the other end into the TV.
- 2 Plug the power cord of the TV (3) into an AC outlet.
- 3 Switch the input channel of the TV to external input.
- 4 Set up the TV configuration system. For more information, see **Selecting the Dual Display mode** (page 83).

 See the manual supplied with your peripheral for more information on installation and use.

If you insert a DVD in your DVD-ROM drive to watch a video on your TV, the **<Fn>+<F7>** key combination might not activate the function to toggle between your LCD and TV.

### Solution:

1. Eject your DVD from your computer.
2. Once the DVD is ejected, toggle between your LCD and your TV with the combination **<Fn>+<F7>**.

Your image displays now on both LCD and TV. Re-insert your DVD to launch your DVD software.

If the display resolution of your computer is more than 1024 x 768 pixels, a part of the image cannot be displayed on your TV. The hidden area on your TV can be seen by moving the cursor on your computer. If you want to display the full image, change the display resolution of your computer to **1024 x 768** pixels or lower.

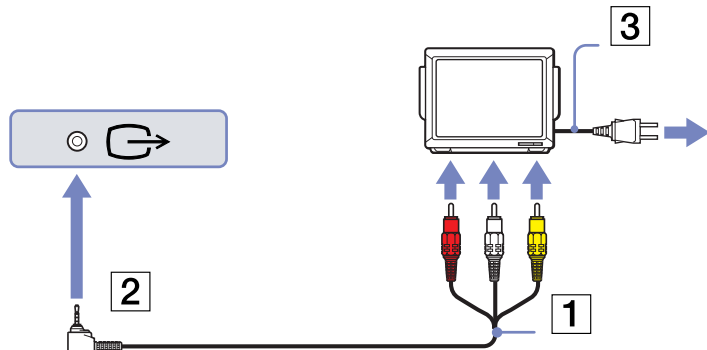

To connect a TV to a docking station, proceed as follows:

- 1 Attach a docking station to your computer, as described in **Attaching your computer to a docking station (page 71)**. Plug one end of the audio/video cable (1) (optional) into the Audio out (R - L) and Video out connectors (2) on your docking station and the other end into the Audio (R - L) and Video connectors on your TV.
- 2 Plug one end of the S-Video cable (3) (optional) into the S-Video out connector (4) and the other end into the S-Video connector on your TV.
- 3 Switch the input channel of the TV to external input.
- 4 Set up the TV configuration system. For more information, see **Selecting the Dual Display mode (page 83)**.

 **Which cable can I use to connect my VAIO equipped with an Audio/Video port to a TV?** You need to use an AV cable which has a minijack connector on one end and 3 RCA (also called cinch) connectors on the other end. For example, the **Sony VMC-20FR** which is available via direct sales and various retailers. Please note that not all TVs have RCA in. If your TV does not have RCA in, you need an RCA to Scart converter (provided of course that your TV has a Scart in). If your VAIO has an S-video port, you can use this port as an alternative means of connection. Please have a look at the **Knowledge Bases** on the [www.vaio-link.com](http://www.vaio-link.com) website.

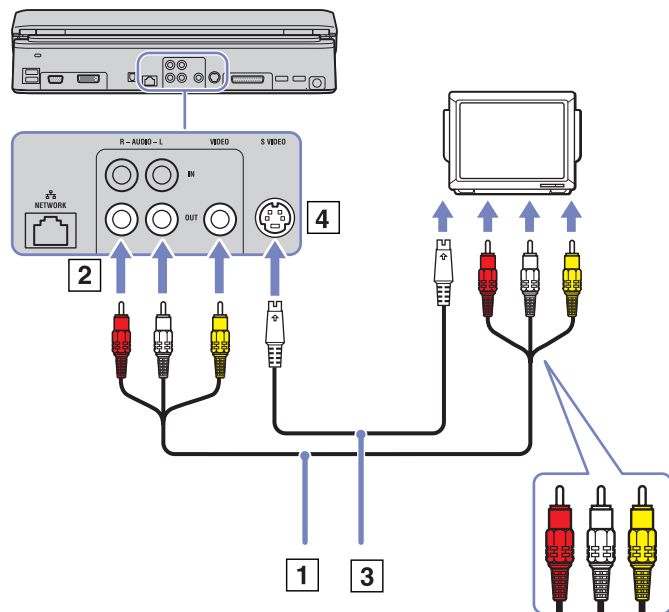





## Connecting a projector

You can connect a projector (such as the Sony LCD projector) directly to your computer or via a docking station.

To connect a projector, proceed as follows:

- 1 Plug the RGB signal cable (1) into the monitor/VGA connector (2) identified by the  symbol.
- 2 Plug the audio cable (3) (not supplied) into the earphone connector (4) identified by the  symbol.
- 3 Plug the RGB signal cable and the audio cable into the connectors of the projector (5).
- 4 Connect the power cord (6) of the projector into an AC outlet.

 Under certain circumstances, you may not be able to display the computer LCD screen and an external display or a projector at the same time.

You can toggle the output between the computer LCD screen and the external monitor by pressing the key combination **<Fn>+<F7>**.

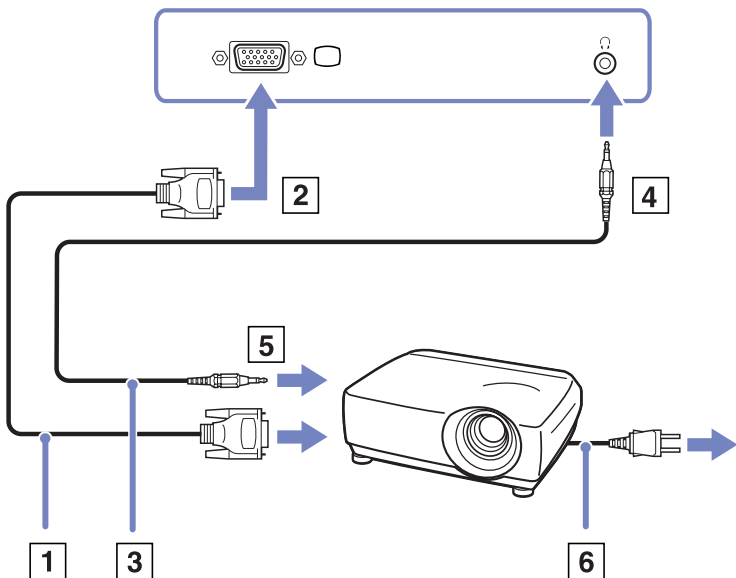

## Selecting display modes

This model uses the MOBILITY RADEON video controller. You can select which display is used when the computer is connected to an external display. When you connect an external display, you can switch the display between your computer's LCD and the external monitor.

Before you can select a display, you need to shut down your computer, connect the external display (FDP (Flat Display Panel), panel or monitor to your computer, and restart.

To select a display, proceed as follows:

- 1 Click the **Start**, then **Control Panel**.  
The **Control Panel** appears.
- 2 Click **Appearance and Themes**, and then select **Display**.  
The **Display Properties** dialog box appears.
- 3 Click the **Settings** tab.
- 4 Click the **Advanced** button.  
The **Sony Notebook LCD and MOBILITY RADEON Properties** dialog box appears.
- 5 Click the **Displays** tab.  
Select the **Monitor, Panel** or **FPD** icon.
- 6 Click **Apply** and then **OK**.

 You may not be able to display the computer LCD screen and an external display or a projector at the same time, depending on the types of computer displays and projectors you are using.

Before turning on the computer, turn on the peripheral device(s).

## Using the Dual Display function

The dual display function allows you to distribute portions of your desktop across separate displays. For example, if you have an external monitor attached to the monitor connector, your LCD display and the monitor can function as a single desktop.

You can move the cursor from one display to the other. This allows you to drag objects, such as an open application window or a toolbar, from one display to the other.

This configuration of a single desktop distributed across separate displays, is referred to as a virtual desktop.

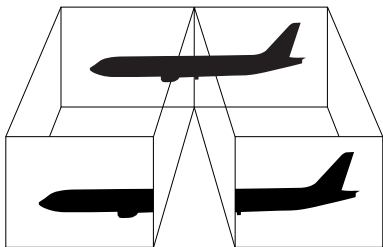

 Your monitor or TV hardware may not support the Dual Display function.

Certain software applications may not be compatible with Dual Display settings.

Make sure that your computer does not enter **Standby** or **Hibernate** mode while you are using Dual Display mode, otherwise your computer may not return to **Normal** mode.

If you set different colours on each display, do not divide one single window on two displays, otherwise your software may not work properly.

Set fewer colours or a lower resolution for each display.

## Selecting the Dual Display mode

To select the Dual Display mode, proceed as follows:

- 1 Click the **Start** button on the **Windows** taskbar.
- 2 Click **Control Panel** and then **Appearance and Themes**.
- 3 Click the **Display** icon and then the **Settings** tab.
- 4 Click the display marked **2** and select the **Extend my Windows desktop onto this monitor** check box.
- 5 Click **Apply** and then **OK**.

 Your monitor or TV hardware may not support the Dual Display function.

## Setting the colours and resolution for each display

You can set the display colours and resolution for each display that is part of a virtual desktop.

To set the display colours and resolution for each display, proceed as follows:

- 1 Click the **Start** button on the **Windows** taskbar.
- 2 Click **Control Panel** and then **Appearance and Themes**.
- 3 Click the **Display** icon and then the **Settings** tab.
- 4 Click the display you want to change (1 or 2): display colours or resolution.
- 5 Select an option from the **Color quality** list to change colours.
- 6 Use the slider in the **Screen resolution** window to adjust the resolution.
- 7 Click **Apply** and then **OK**.

## *Customising the virtual desktop*

You can customise the Dual Display mode by changing the position of the two monitors comprising the virtual desktop.

To customise Dual Display mode, proceed as follows:

- 1 Click the **Start** button on the **Windows** taskbar.
- 2 Click **Control Panel** and then **Appearance and Themes**.
- 3 Click the **Display** icon and then the **Settings** tab.
- 4 Drag the monitor icons to match the physical arrangement of your monitors. The two monitor icons must be connected to create a virtual desktop.
- 5 Click **Apply** and then **OK**.

## *Deactivating the Dual Display function*

To deactivate the Dual Display function, proceed as follows:

- 1 Click the **Start** button on the **Windows** taskbar.
- 2 Click **Control Panel** and then **Appearance and Themes**.
- 3 Click the **Display** icon and then the **Settings** tab.
- 4 Click the display 2 and deselect the **Extend my Windows desktop onto this monitor** option.

 For switching from Primary to Secondary display, see the section **Selecting display modes** ([page 81](#)).

## Connecting external speakers

Using external speakers can enhance the sound quality of your computer. Depending on your model\*, your notebook is delivered with a set of external speakers. If your notebook is not delivered with external speakers, you can always connect other external speakers.

To connect the external speakers delivered with your notebook, proceed as follows:

- 1 Plug the speaker cables into the speaker ports on the docking station.
- 2 Plug the USB cable attached to one speaker, into one of the 4 USB ports  on the docking station.
- 3 Plug the volume cable attached to the other speaker, into the volume port on the docking station.
- 4 Turn down the volume of the speakers before you turn them on.

To connect other external speakers, proceed as follows:

- 1 Plug the speaker cable (1) into the headphone connector (2).
- 2 Plug the other end of the speaker cable into the external speaker (3).
- 3 Turn down the volume of the speakers before you turn them on.

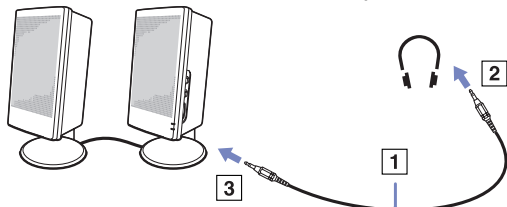

 Make sure your speakers are designed for computer use.

Do not place floppy disks on the speakers; their magnetic field may damage the data on the disks.

\* Read the printed **Specifications** document for more information.

## Troubleshooting sound

### *My speakers are not producing sound*

If you have problems with the sound, check the printed **Guide to Troubleshooting and Recovering your VAIO System** and the VAIO-Link website ([www.vaio-link.com](http://www.vaio-link.com)).

### *Connecting an external microphone*

If you need to use a sound input device, for example to chat on the internet, you need to plug in an external microphone.

To connect an external microphone, proceed as follows:

Plug the microphone cable (1) into the microphone connector (2) identified by the  symbol.

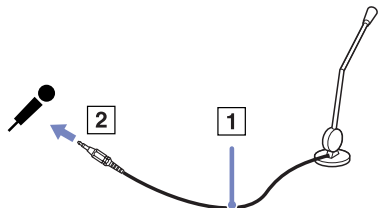

 Make sure your microphone is designed for computer use.

## Connecting a Universal Serial Bus (USB) device

You can connect a USB device (for example, a mouse, floppy disk drive, keyboard, printer) to your computer.

USB devices are hot plug and play devices. You do not need to shut down your computer prior to connecting these devices unless the manual supplied with the device states otherwise.

For some USB devices you need to install the software before you connect the device. Not following this procedure might cause the device not to work properly. For more information, check the manual provided with the USB device.

When you are playing a DVD (video or audio) and you want to remove a USB device, such as USB-compatible speakers, make sure you stop the DVD first. Removing a USB-compatible device during DVD (video or audio) playback may cause a malfunction.

To prevent your computer and/or USB devices from damage, observe the following:

- When moving your computer with USB devices connected, avoid any shock or force to the USB connectors.
- Do not put your computer into a bag or carrying case when it has USB devices connected.
  
- Connecting a USB mouse** ([page 88](#))
- Connecting a USB floppy disk drive** ([page 89](#))



## Connecting a USB mouse

To connect a USB mouse, proceed as follows:

- 1 Choose the USB connector (1) you prefer to use.
- 2 Plug the USB mouse cable (2) into the USB connector.
- You can use your USB mouse (3).

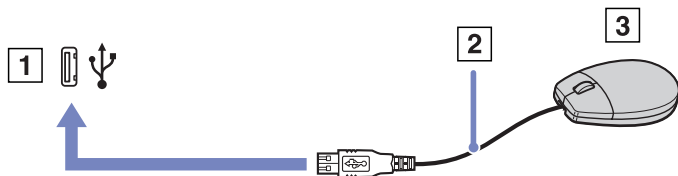

 The VAIO USB mouse software driver is preinstalled on your computer, therefore, you only need to plug the USB mouse into the USB connector and you can start working.

## Connecting a USB floppy disk drive

As an optional extra, you can purchase a USB floppy disk drive and connect it to your computer.

To connect a USB floppy disk drive, proceed as follows:

- 1 Choose the USB connector you prefer to use.
- 2 Plug the USB floppy disk drive cable into the USB connector. The VAIO logo on the disk drive should be facing up. Your USB floppy disk drive is now ready for use.

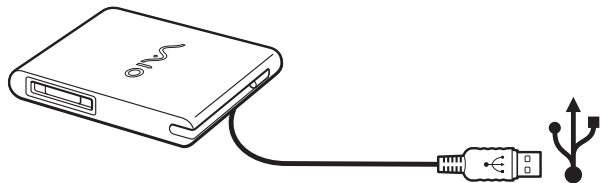

 When using a USB floppy disk drive, do not apply force on the USB connector. This may cause a malfunction.

To remove a USB floppy disk drive, proceed as follows:

- If your computer is on, wait until the floppy drive LED indicator turns off and then unplug the USB cable. If the floppy disk drive is not removed properly, your system may crash and you may lose any unsaved data.
- If your computer is off, you can unplug the USB cable directly from the computer.

## Inserting a floppy disk

To insert a floppy disk, proceed as follows:

- 1 Hold the disk (1) with the label side facing up.
- 2 Gently push the disk into the drive (2) until it clicks into place.

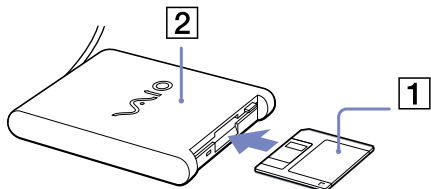

## Removing a floppy disk

To remove a floppy disk, proceed as follows:

When you have finished using the floppy disk, wait until the LED indicator (1) turns off and then press the eject button (2) to remove the disk.

 Before pressing the eject button, make sure that the LED indicator is turned off.

If the disk does not come out by pressing the eject button, disconnect the floppy disk drive from the computer.

**!** Do not press the eject button while the LED indicator is on. It may damage the floppy disk.

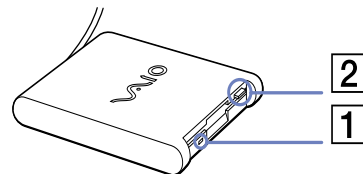

## Troubleshooting floppy disks

### *My USB floppy disk drive cannot write to a floppy disk*

If you have problems with the floppy disk drive, check the printed **Guide to Troubleshooting and Recovering your VAIO System** and the VAIO-Link website ([www.vaio-link.com](http://www.vaio-link.com)).

### *The optional PCGA-UFD5/A (USB) floppy disk drive is not recognised as drive A*

To set the UFD5/A to A, proceed as follows :

- 1 Turn the system power on and connect the UFD5/A.
- 2 Select **Control Panel** from the **Start** menu.
- 3 Click **Performance and Maintenance** and then **System**.
- 4 Select the **Hardware** tab, then click **Device Manager**.
- 5 Select **Universal Serial Bus controllers**, then **Y-E Data USB Floppy**.
- 6 From the **Action** menu, click **Uninstall**.
- 7 Keep clicking **OK** until the **Confirmation of deletion of device** message appears.
- 8 Select **Scan for hardware changes** from the **Action** menu.  
The UFD5/A is recognised as drive A.

## Connecting a printer

You can connect a Windows-compatible printer to your computer to print documents.

### Connecting a printer using the USB connector

You can connect a USB printer compatible with your version of Windows to your computer.

To connect a printer using the USB connector, proceed as follows:

- 1 Plug a USB printer cable (1) into one of the USB connectors (2) on your computer.  
A USB connector is identified by the  symbol on your computer and printer.
- 2 Plug the printer power cord into an AC outlet (3).

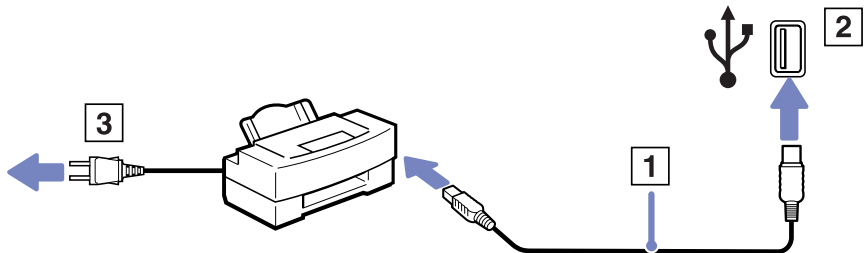

## Connecting a printer using the printer connector

To connect a printer using the printer connector, proceed as follows:

- 1 Plug the printer cable (1) supplied with the printer into the printer connector (2) identified by the  symbol.
- 2 Plug the printer power cord (3) into an AC outlet.

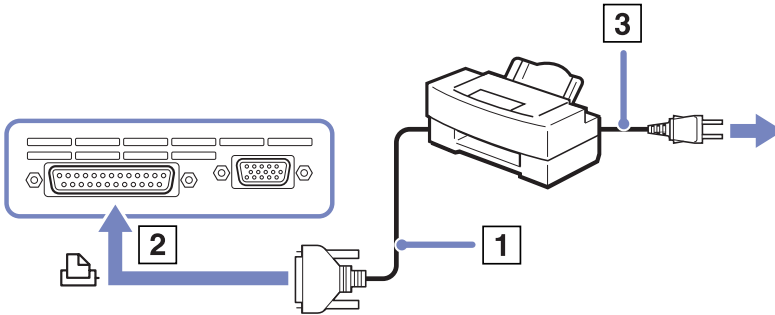

 Turn off your computer and the printer, unplug the AC adapter and the power cord before connecting the printer.

If you have problems printing, check the printed **Guide to Troubleshooting and Recovering your VAIO System**; the documentation delivered with your printer; and the VAIO-Link website ([www.vaio-link.com](http://www.vaio-link.com)).

## Connecting an i.LINK device

Your computer includes an i.LINK (IEEE1394) connector, which you can use to connect to an i.LINK device such as a digital video camera recorder or to connect two VAIO notebooks in order to copy, delete or edit files.

The i.LINK connector of your computer does not supply power to external devices generally powered by i.LINK connectors.

The i.LINK connector supports transfer rates up to 400 Mbps; however, the actual transfer rate depends on the transfer rate of the external device.

The i.LINK features available may vary depending on the software applications you use. Refer to the documentation that came with your software for more information.

i.LINK cables compatible with your VAIO computer include cables with the following part numbers:

VMC-IL4415A (a 1.5 meter cable with a 4-pin connector at each end), VMC-IL4408Series (a 0.8 meter cable with a 4-pin connector at each end).

- ❑ **Connecting a digital video camera recorder** ([page 95](#))
- ❑ **Connecting two VAIO notebooks** ([page 95](#))

 An i.LINK connection with other compatible devices is not fully guaranteed.

The i.LINK connection varies depending on the software applications, operating system and i.LINK compatible devices you use. Refer to the documentation that came with your software for more information.

Check the working conditions and OS compatibility of i.LINK-compatible PC peripherals (HDD, CD-RW drive etc.) before you connect them to your computer.

## Connecting a digital video camera recorder

To connect a digital video camera recorder, proceed as follows:

- 1 Plug one end of the i.LINK cable (1) into the i.LINK connector (2) of the computer and the other end into the DV Out connector (3) on the digital video camera recorder.
- 2 Launch the **DVgate Plus** application.

 On Sony digital video cameras, connectors labelled **DV Out**, **DV In/Out** or **i.LINK** are i.LINK-compatible.

The Sony digital video camera recorder is an example; your digital video camera recorder may need to be connected differently.

If your digital video camera recorder includes a Memory Stick slot, you can copy images from it to your computer via a Memory Stick. To do so, simply copy images on the Memory Stick, then use a special PC Card adapter to insert it into your computer.

You cannot access the pictures stored on a Memory Stick when using an i.LINK connection.

## Connecting two VAIO notebooks

You can copy, edit or delete files on another VAIO computer to your computer with an optional i.LINK cable.

You can also print a document on a printer connected to another VAIO computer.

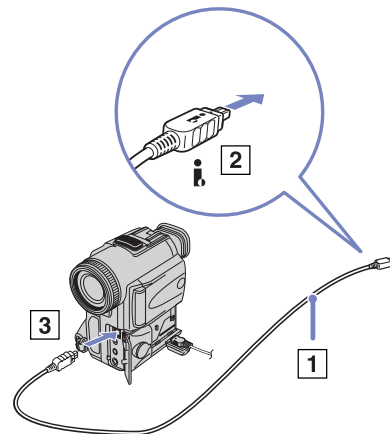
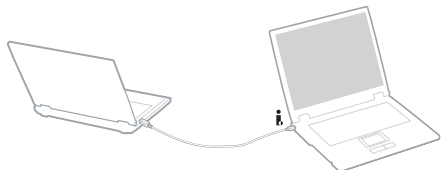



## *Troubleshooting i.LINK devices*

If you have problems with your i.LINK device, check the printed **Guide to Troubleshooting and Recovering your VAIO System**, the documentation delivered with the device, and the VAIO-Link website ([www.vaio-link.com](http://www.vaio-link.com)).

## Connecting to a network (LAN)

You can connect your computer to 10BASE-T/100BASE-TX and 1000BASE-T\*-type networks via an Ethernet network cable. For the detailed settings and devices needed to connect to the network, consult your Network Administrator.

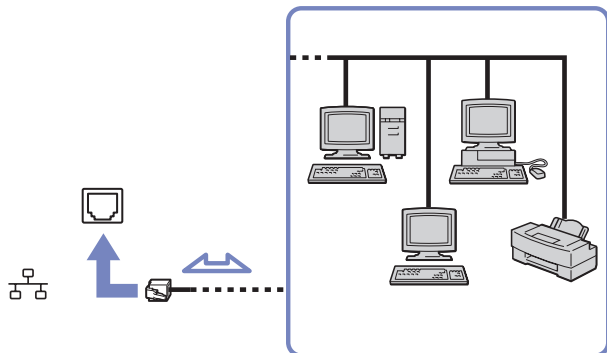

\* Depending on your model.



The default settings make your computer able to connect to the network.

If the main unit is docked, you can only use the Ethernet network connector on the docking station.

For more information about connecting your computer to the network, please consult the Hardware troubleshooting section on [www.vaio-link.com](http://www.vaio-link.com).

! Telephone lines cannot be connected to the NETWORK (LAN) connector on your computer. If these connectors are connected to the telephone lines mentioned below, high electric current to the connectors may cause damage, overheating or fire.

- Home (intercom speakerphone) or business-use telephone lines (multi-line business telephone);
- Network lines such as 10BASE-T and 100BASE-TX lines;
- Public telephone subscriber line;
- PBX (private branch exchange);
- Lines other than those mentioned above.

! Do not plug a phone cable into your computer network jack.

## Upgrading your VAIO computer

Your computer and memory modules use high precision components and electronic connectors technology. To avoid the invalidation of your guarantee by mishandling, it is recommended that:

- You contact your dealer to install a new memory module.
- You do not install it yourself, if you are not familiar with upgrading memory on a computer.
- You do not touch the connectors or open the memory panel.
- Contact VAIO-Link if you need assistance.

### Adding and removing memory

In the future you may want to change or add memory modules in order to expand the functionality of your computer. You can increase the memory by installing optional memory modules. Depending on the configuration of your computer, the number of available slots can vary.

Some models have a vacant expansion slot to increase the ease of adding memory. Read the **Specifications** sheet for more information.

Be careful when changing memory. Mistakes on installation or removal of the memory module may cause a malfunction.

Electrostatic discharge can damage electronic components. Before touching a memory expansion board, ensure the following:

- Handle the memory module gently.
- The procedures described in this document assume familiarity with the general terminology associated with personal computers and with the safety practices and regulatory compliance required for using and modifying electronic equipment.
- Disconnect the system from its power source (that is, battery or AC adapter) and from any telecommunication links, networks, or modems before you open the system. Failure to do so may result in personal injury or equipment damage.

- ❑ Electrostatic Discharge (ESD) can damage memory modules and other components. Install the memory Module only at an ESD workstation. If such a station is not available, do not work in a carpeted area, and do not handle materials that produce or hold static electricity (cellophane wrappers, for example). Ground yourself by maintaining contact with an unpainted metal portion of the chassis while performing the procedure.
- ❑ Do not open the memory module package until you are ready to change the module. The package protects the module from ESD.
  - ! Use the special bag delivered with the memory module or wrap the module in aluminium foil to protect it from electrostatic discharge.
  - ! Introducing any liquids or any foreign substances or objects into the memory slots, or other internal components of the computer, will result in damage to the computer and any repairs will be out of warranty.
  - ! Do not place the memory module in places subject to:
    - Heat sources such as radiators or air ducts,
    - Direct sunlight,
    - Excessive dust,
    - Mechanical vibration or shock,
    - Strong magnets or speakers that are not magnetically shielded,
    - Ambient temperature of more than +35°C or less than +5°C,
    - High humidity.
  - ! Handle the memory module with care. To avoid injuries to your hands and fingers, do not touch the edges of the components and circuit boards inside your computer.

## Removing and installing a memory module

There is one memory slot at the bottom of your notebook and one under the keyboard.

To change or add a memory module, proceed as follows:

- 1 Shut down your computer and disconnect all peripheral devices.
- 2 Unplug the computer and remove the battery pack.
- 3 Wait until the computer cools down.
- 4 Unscrew the central screw at the bottom of your computer.

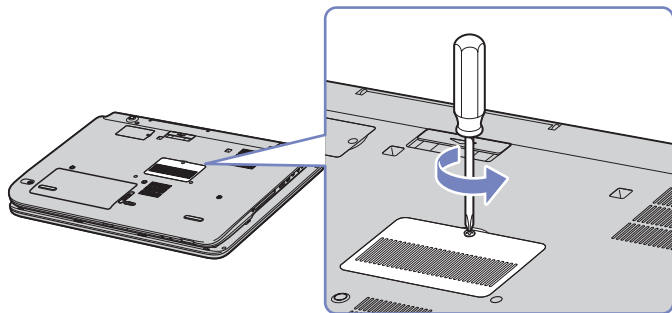

- 5 Remove the memory module:

- Pull the tabs in the direction of the arrows. The memory module is released.
- Pull the memory module in the direction of the arrow.

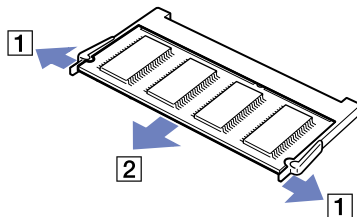

- 6 Unscrew the 2 screws next to the memory slot.

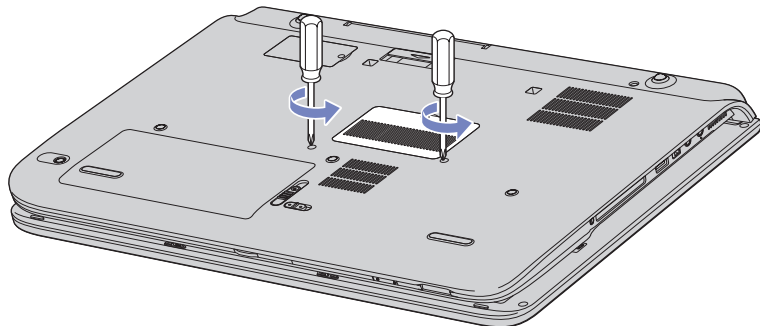

- 7 Turn your computer around and lift the cover.
- 8 Introduce a sharp object (such as a fine screwdriver) between the keys indicated on the picture (1) and push gently upwards.

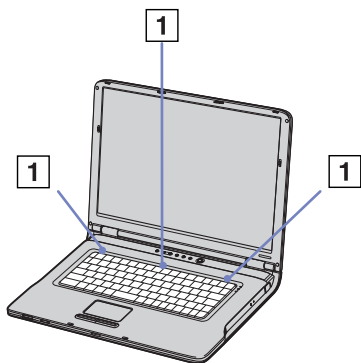

- Lift the keyboard from the LCD display side and gently turn it over the touchpad. Be careful not to detach the cable when lifting the keyboard.



- Touch a metal object (such as the connector panel on the back of your computer) to discharge static electricity.

- Remove the memory module:

- Pull the tabs in the direction of the arrows (1).  
The memory module is released.

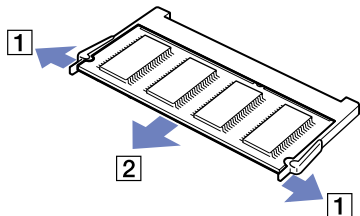

- Pull the memory module in the direction of the arrow (2).

- Remove the new memory module from its packaging.

13 Install the memory module. Be careful not to touch the other components on the motherboard.

- ❑ Slide the memory module into the slot.

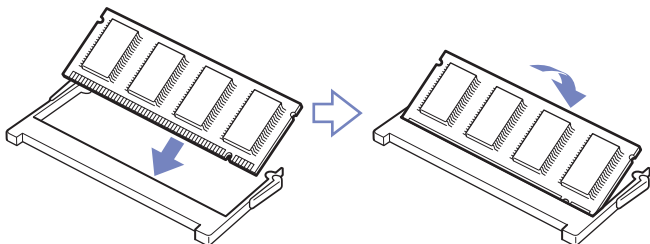

- ❑ Snap the connectors into place when the board is correctly seated.



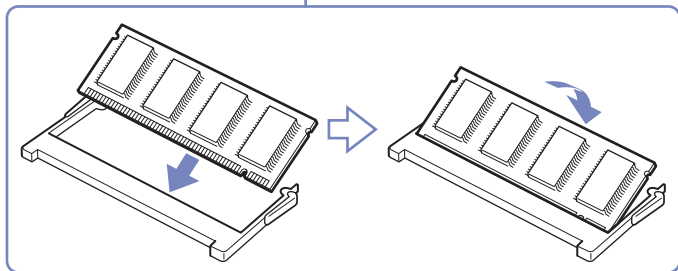
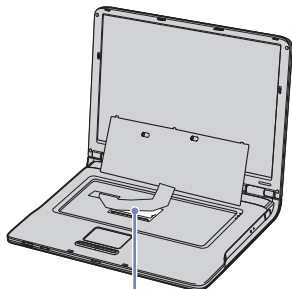

14 Gently replace the keyboard, then press it into your computer.



**15** Close the computer cover, then tighten the screws on the bottom of the computer.

**16** Reinsert the battery and turn the computer on.

## *Viewing the amount of memory*

To view the amount of memory, proceed as follows:

- 1 Turn on the computer.
- 2 Go to **Sony Notebook Setup** via the **Start** menu.  
The **Sony Notebook Setup** dialog box appears.
- 3 In the **About this Computer** tab you can view the amount of system memory. If the additional memory does not appear, repeat the whole procedure and restart the computer.

## Getting help

This section describes how to get help and support if something goes wrong with your computer. Sony offers you many support options for your computer.

### *Sony support options*

Please see the section **Documentation pack (page 10)** for details on the non-printed and printed documentation delivered with your computer, as well as further sources of reference.

### *Other sources of information*

- ❑ Go to **Start > Help and Support** for VAIO support information as well as tips and tricks.
- ❑ Go to the **online help files** that accompany your software for instructions on using the software.
- ❑ **VAIO-Link website and e-Support:** if you have any problem with your computer, you can access the VAIO-Link website for troubleshooting. Go to: [www.vaio-link.com](http://www.vaio-link.com).
- ❑ Visit the other Sony websites:
  - ❑ [www.club-vaio.com](http://www.club-vaio.com) if you want to know more about VAIO and become part of the growing VAIO community.
  - ❑ [www.sonystyle-europe.com](http://www.sonystyle-europe.com) for online purchases.
  - ❑ [www.sony.net](http://www.sony.net) for other Sony products.



You need to set up an internet connection before you can access the online features described here.

## *e-Support*

### *What is e-Support?*

You have searched our user guides and website ([www.vaio-link.com](http://www.vaio-link.com)) but have not found an answer to your question/issue? e-Support is the ideal solution for you!

Our e-Support Web Portal is an interactive website on which you can submit any technical query you may have regarding your VAIO and receive answers from our dedicated support team.

Every submitted query will result in a unique 'case number' to ensure smooth communication between yourself and the e-Support Team.

### *Who can use e-Support?*

All registered VAIO customers are entitled to unlimited access to the VAIO-Link e-Support Web Portal.

### *How can I access the e-Support portal?*

When you register your VAIO computer online at Club-VAIO ([www.club-vaio.com](http://www.club-vaio.com)), you will automatically receive an email with the link to the e-Support Web Portal, your Customer ID and some basic explanation a few hours later.

All you need to do is activate your account by clicking on the provided link in the email.

You are now ready to create your first case!

You can access the e-Support Web Portal from any computer with an active internet connection.

A complete help file is available on the e-Support Web Portal to help you use our e-Support Service.

### *Can I submit questions in my native language?*

Since you are interacting with our e-Support Team through a portal, which connects you directly to our central database, e-Support will only accept and deal with queries submitted in English.

### *Can I submit my questions at any time?*

Yes, you can submit your questions 24/7, but please keep in mind that our e-Support Team can only treat your queries from Monday till Friday between 8am and 6pm.

### *Is there a cost involved for using e-Support?*

No, this is a complete free of charge service offered to all registered VAIO customers!

### *How do I know when the e-Support Team has handled my query/case?*

As soon as your case has been dealt with by our e-Support Team, you will receive an email, notifying you that your case has been updated.

## Precautions

This section describes safety guidelines and precautions to help you protect your computer from potential damage. Please contact VAIO-Link if you need assistance.

- ❑ **On handling the hard disk** ([page 111](#))
- ❑ **On handling the LCD screen** ([page 111](#))
- ❑ **On using the power source** ([page 112](#))
- ❑ **On handling your computer** ([page 112](#))
- ❑ **On handling floppy disks** ([page 114](#))
- ❑ **On handling discs** ([page 114](#))
- ❑ **On using the battery pack** ([page 115](#))
- ❑ **On using headphones** ([page 116](#))
- ❑ **On handling Memory Sticks** ([page 116](#))

## On handling the hard disk

The hard disk has a high storage density and reads or writes data in a short time. However, it can be easily damaged by mechanical vibration, shock or dust.

Although the hard disk has the internal safety device to prevent losing data due to mechanical vibration, shock or dust, you should be careful when handling your computer.

To avoid damaging your hard disk:

- Do not subject your computer to sudden movements.
- Keep the computer away from magnets.
- Do not place your computer in a location subject to mechanical vibration or in an unstable position.
- Do not move your computer while the power is on.
- Do not turn off the power or restart the computer while reading or writing data to disk.
- Do not use your computer in a place subject to extreme changes in temperature.
- Do not move your computer while the system is in **Standby** mode.

 If the hard disk is damaged, the data cannot be restored.

## On handling the LCD screen

- Do not leave the LCD facing the sun as it can damage the LCD. Be careful when using the computer near a window.
- Do not scratch the LCD or exert pressure on it. This could cause malfunction.
- Using the computer in low temperature conditions may produce a residual image on the screen. This is not a malfunction. When the computer returns to normal temperature, the screen returns to normal.
- A residual image may appear on the screen if the same image is displayed for a lengthy period of time. The residual image disappears in a while. You can use a screensaver to prevent residual images.
- The screen becomes warm during operation. This is normal and does not indicate a malfunction.



- ❑ The LCD is manufactured using high-precision technology. You may, however, see tiny black points and/or bright points (red, blue, or green) that continuously appear on the LCD. This is a normal result of the manufacturing process and does not indicate a malfunction.
- ❑ Avoid rubbing the LCD screen, as this can damage the screen. Use a soft, dry cloth to wipe the LCD screen.

### *On using the power source*

- ❑ See the printed **Specifications** sheet to check the power operation of your VAIO.
- ❑ Do not share the AC outlet with other power-consuming equipment, such as a photocopier or shredder.
- ❑ You can purchase a power strip with a surge protector. This device prevents damage to your computer caused by sudden power surges, in an electrical storm, for example.
- ❑ Do not place heavy objects on the power cord.
- ❑ To disconnect the cord, pull it out by the plug. Never pull the cord itself.
- ❑ Unplug your computer from the wall outlet if you are planning to not use the computer for a long time.
- ❑ Make sure that the socket outlet is easily accessible.
- ❑ When the AC adapter is not used, unplug it from the AC outlet.
- ❑ Use only the supplied AC adapter. Do not use any other AC adapter.

### *On handling your computer*

- ❑ Clean the cabinet with a soft cloth, which is either dry or lightly moistened with a mild detergent solution. Do not use any type of abrasive pad, scouring powder, or solvent such as alcohol or benzine, as these may damage the finish of your computer.
- ❑ Should you drop a solid object or any liquid onto the computer, shut down your computer and then unplug it. You may want to have the computer checked by qualified personnel before operating it again.
- ❑ Do not drop the computer or place heavy objects on top of the computer.

- ❑ Do not place your computer in a location subject to:
  - ❑ Heat sources, such as radiators or air ducts,
  - ❑ Direct sunlight,
  - ❑ Excessive dust,
  - ❑ Moisture or rain,
  - ❑ Mechanical vibration or shock,
  - ❑ Strong magnets or speakers that are not magnetically shielded,
  - ❑ Ambient temperature of more than 35°C or less than 5°C,
  - ❑ High humidity.
- ❑ Do not place electronic equipment near your computer. The electromagnetic field of your computer may cause a malfunction.
- ❑ Provide adequate air circulation to prevent internal heat from building up. Do not place your computer on porous surfaces such as rugs or blankets, or near material such as curtains or draperies that may block its ventilation slots.
- ❑ The computer uses high-frequency radio signals and may cause interference to radio or TV reception. Should this occur, relocate the computer a suitable distance away from the set.
- ❑ Use only specified peripheral equipment and interface cables; otherwise, problems may occur.
- ❑ Do not use cut or damaged connection cables.
- ❑ If the computer is brought directly from a cold location to a warm one, moisture may condense inside your computer. In this case, allow at least one hour before turning on your computer. If any problems occur, unplug your computer and contact VAIO-Link.
- ❑ Make sure you disconnect the power cord before cleaning the computer.
- ❑ As you may lose important data once your computer is damaged, you should back up your data regularly. You can restore most of the original application programs from the supplied disc (read the **Guide to Troubleshooting and Recovering your VAIO System** for details).

## On handling floppy disks

- ❑ Do not open the shutter manually or touch the surface of the floppy disk.
- ❑ Keep floppy disks away from magnets.
- ❑ Keep floppy disks away from direct sunlight and other sources of heat.
- ❑ Keep floppy disks away from any liquid. Do not let floppy disks get wet. When you are not using the floppy disk, always remove it from the floppy disk drive and use a storage case.
- ❑ If floppy disks comes with a label, make sure that the label is properly attached. If the edge of the label is curled up, the label may stick to the inside of the floppy disk drive and cause a malfunction or damage your floppy disk.

## On handling discs

- ❑ Do not touch the surface of the disc.
- ❑ Do not drop or bend the disc.
- ❑ Fingerprints and dust on the surface of a disc may cause read errors. Always hold the disc by its edges and central hole, as shown:

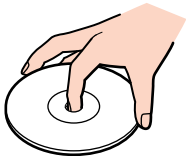

- ❑ Proper care of the disc is essential to its continuous reliability. Do not use solvents such as benzine, thinning agents, commercially available cleaners or anti-static spray, as they may cause damage to the disc.
- ❑ For normal cleaning, hold the disc by its edge and use a soft cloth to wipe the surface from the centre out.

- ❑ If the disc is badly soiled, moisten a soft cloth with water, wring it out well, and use it to wipe the surface of the disc from the centre out. Wipe off any remaining moisture with a dry soft cloth.
- ❑ Never put stickers on discs. This will affect the use of the disc irreparably.

### *On using the battery pack*

- ❑ Never leave the battery pack in temperatures above 60°C, such as in a car parked in the sun or under direct sunlight.
- ❑ Battery life is shorter in a cold environment. This is due to decreased battery efficiency at low temperatures.
- ❑ Charge the batteries at temperatures between 10°C to 30°C. Lower temperatures require a longer charging time.
- ❑ While the battery is in use or being discharged, the battery pack heats up. This is normal and is not cause for concern.
- ❑ Keep the battery pack away from all sources of heat.
- ❑ Keep the battery pack dry.
- ❑ Do not open or try to disassemble the battery pack.
- ❑ Do not expose the battery pack to any mechanical shock.
- ❑ If you are not using the computer for an extended period of time, remove the battery pack from the computer to prevent damage to the battery.
- ❑ If, after fully charging the battery pack, the battery power is still low, the battery pack may be reaching the end of its life and should be replaced.
- ❑ You do not need to discharge the battery before recharging.
- ❑ If you have not used the battery pack for a considerable amount of time, recharge the battery.

## *On using headphones*

- ❑ **Road safety** – Do not use headphones while driving, cycling, or operating any motorized vehicle. It may create a traffic hazard and is illegal in some areas. It can also be potentially dangerous to play loud music while walking, especially at pedestrian crossings.
- ❑ **Preventing hearing damage** – Avoid using headphones at high volume. Hearing experts advise against continuous, loud and extended play. If you experience a ringing in your ears, reduce the volume or discontinue use.

## *On handling Memory Sticks*

- ❑ Do not touch the Memory Stick connector with your finger or metallic objects.
- ❑ Use only the label supplied with the Memory Stick as a label.
- ❑ Do not bend, drop, or apply strong shock to the Memory Stick.
- ❑ Do not disassemble or modify Memory Sticks.
- ❑ Do not let Memory Sticks get wet.
- ❑ Do not use or store Memory Sticks in a location subject to:
  - ❑ Extremely high temperatures, such as in a car parked in the sun,
  - ❑ Direct sunlight,
  - ❑ High humidity or,
  - ❑ Corrosive substances.
- ❑ Use the storage case supplied with the Memory Stick.

## Trademarks

Sony, Battery Checker, Click to DVD, DVgate Plus, HotKey Utility, Keyboard Utility, Memory Stick Formatter, PictureGear Studio, Prepare your VAIO, SonicStage, SonicStage Mastering Studio, Sony Notebook Setup, VAIO Edit Components, VAIO Launcher, VAIO Media, VAIO Power Management, VAIO Power Management Viewer, VAIO System Information, VAIO Zone, Memory Stick, the Memory Stick logo, VAIO and the VAIO logo are trademarks of Sony Corporation.

Microsoft, Internet Explorer, Windows Movie Maker, Windows Media Player, Windows XP Professional, Windows XP Home Edition, Microsoft Works and the Windows logo are trademarks or registered trademarks of Microsoft Corporation in the U.S. and other countries.

i.LINK is a trademark of Sony used only to designate that a product contains an IEEE1394 connection.

Adobe, Adobe Acrobat Elements, Adobe Acrobat Professional, Adobe Photoshop Album, Adobe Reader, Adobe Premiere Standard and Adobe Photoshop Elements are trademarks of Adobe Systems Incorporated.

MoodLogic is a trademark of MoodLogic, Inc.

Norton Internet Security 2004 and Norton Password Manager 2004 are trademarks or registered trademarks of Symantec Corporation.

RecordNow! is a trademark of Sonic.

WinDVD for VAIO is a trademark of InterVideo, Inc.

Sun Java VM is a trademark of Sun Microsystems, Inc.

Google Toolbar is a trademark of Google.

Yahoo! Messenger is a trademark of Yahoo!.

SafeGuard PrivateDisk is a trademark of Utimaco Software.

My Info Centre contains Macromedia Flash Player software by Macromedia, Inc., Copyright © 1995-2003 Macromedia, Inc. All rights reserved. Macromedia and Flash are trademarks of Macromedia, Inc.

All other names of systems, products and services are trademarks of their respective owners. In the manual, the <sup>TM</sup> or <sup>®</sup> marks are not specified.

Specifications are subject to change without notice. All other trademarks are trademarks of their respective owners.

Please see the printed **Specifications** sheet to see what software is available for your model.